

# Analysis of variance (ANOVA) of polarization degree of chromatic lines in H<sub>2</sub>-Kr mixture

C. GAVRILĂ, I. GRUIA<sup>a,\*</sup>

*Faculty of Building Services and Equipment, Technical University of Civil Engineering Bucharest, Romania*

<sup>a</sup>*Faculty of Physics, University of Bucharest, Romania*

The Monochromatization–effect of light (the so-called M-effect) consists in the reduction of an electronegative–electropositive gas mixtures discharge emission spectrum to only a few (or even one, in the particular case of H<sub>2</sub> - Ne gas mixture) spectral lines, in A.C./D.C. discharges at moderate to high total pressures (tens to hundreds of mbar). The main reaction mechanism is the polar resonant three-body reaction, with the decisive contribution of the electronegative metastable atoms, which play the role of the third particle involved in reaction. The paper deals with the variance analysis of the polarization degree in H<sub>2</sub>-Kr gas mixture ( $V_{H_2}/V_{Ne}=27/38$ ). The calculations were performed for different total pressures values (27,5 torr, 42 torr, 65 torr and 80 torr, respectively) of the gas mixture, taking into account the intensities of three spectral lines ( $\lambda=758,7\text{nm}$ , 760nm and 811nm), which appeared as dominant ones in frame of the M-effect. The calculation method used in the experiment was the “Two-way ANOVA method” which offers the possibility to follow the evolution of physical parameters of interest under different experimental conditions.

(Received July 30, 2014; accepted November 13, 2014)

**Keywords:** M-effect, H<sub>2</sub>-Kr gas mixture, Polarization Degree (PD), Analysis of variance (ANOVA) method

## 1. Introduction

Our studies, performed for (Kr+H<sub>2</sub>) gas mixtures plasma in a RF discharge, at pressures varying in the range of 27 to 80 torr, have put in evidence a clear reduction of the krypton emission spectrum to practically only three spectral lines, considered as dominant in the frame of M-effect namely 758,7nm, 760nm and 811nm, respectively [1].

Due to the fact that the modified spectrum is usually reduced to some dominant lines, the phenomenon was called the “Monochromatization-effect” (M-effect). It is interesting to notice that a kind of “cleaning” effect of the emission spectrum appears also in the case of the nitrogen plasma in which was added a very small quantity of hydrogen but yet there are important differences concerning the experimental conditions and the reaction mechanisms between the two types of plasma discharges [2, 3].

For the gas mixtures in which the electronegative gas has a strong electronic affinity, like the chlorine atoms, the generation reaction for the M-effect could be binary in the classical sense of the Landau-Zenner theory [4-6].

Recent studies have also indicated the fact that the M-effect could be present not only in binary but also in multiple electronegative-electropositive gas mixtures in AC discharges (DBD-type), as it is shown in Figs. (1, 2, 3) [7, 8].

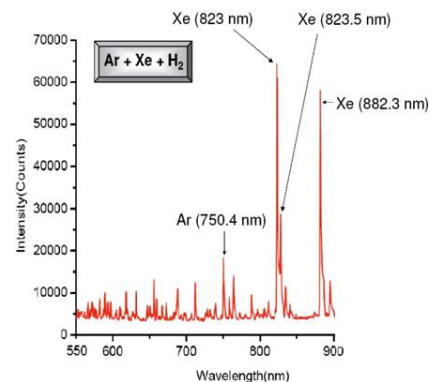

Fig. 1 Emission spectrum of the M-effect in (Ar-Xe + 35% H<sub>2</sub>) mixture DBD plasma at 50 torr total pressure.

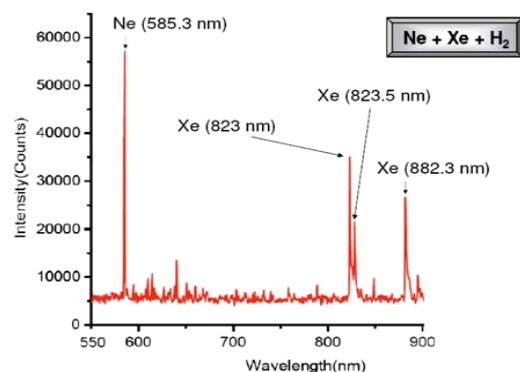

Fig. 2 Emission lines of the M-effect in (Xe-Ne+ 35% H<sub>2</sub>) mixture discharge at 80 torr total pressure.

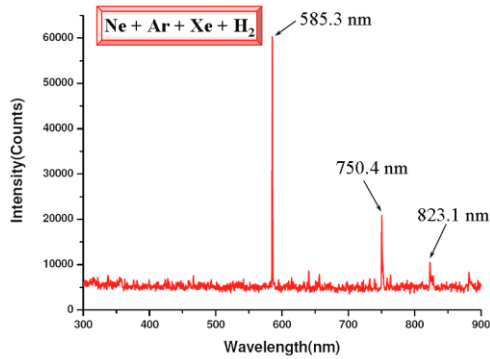
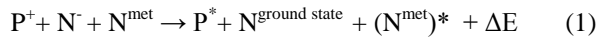

Fig. 3 Emission spectrum of the M-effect in (Ne-Ar-Xe + 50% H<sub>2</sub>) mixture DBD plasma at 80torr total pressure.

The main reaction mechanism of the M-effect is represented by the resonant three-body polar reaction between the ionized, excited and ground state atoms, with the important contribution of the electronegative gas metastable atoms [9-19].

The general form of the reaction is the following:



where P and N are the symbols for the atoms of electropositive and electronegative gases respectively, P<sup>+</sup> refers specifically to positive ion, N<sup>-</sup> is for the negative ion, N<sup>met</sup> designates the metastable negative atom before the collision; then (N<sup>met</sup>)<sup>\*</sup> is the symbol of the excited electronegative atom standing in a upper state energy that the one of the metastable level, P<sup>\*</sup> is the electropositive atom in an excited state after interaction and ΔE is the notation in use for the reaction energy defect.

Usually, the probability of a three-body reaction, in contrast with a two-body one, is very small, but there are some specific features of the gas mixture discharge used that determine a significant rise of the probability to this particular reaction, namely:

- The co - existence of negative and positive ions which provides a high probability of collisions due to the attraction of Colombian forces of opposite sign particles.
- The relatively high total gas pressure (tens to hundred mbar), which ensures a higher probability of the three-body interaction.
- The existence of metastable-state atoms which are long-lifetime species, a feature favoring their participation in this three-body reaction.

When the collision reaction (1) takes place (equivalent to a reaction probability equal to 1), a monochromatic light is emitted via the radiative des-excitation of the P<sup>\*</sup> atoms. This happens when the energy defect of reaction (1) is ΔE=0 eV (ideally). The energy defect is given by the difference in the energy of the participating particles before the three-body interaction and after it: the positively ionized and excited neutral atoms, P<sup>+</sup> and P<sup>\*</sup>, respectively, and the metastable-state atoms N<sup>met</sup> and N<sup>met\*</sup> (the negative ions have, obviously, negative energy values when calculations were made). The result of the energy balance

of the reaction (1) is ΔE calculated energy defect. The M-effect can be obtained for those combinations of P<sup>\*</sup> and N<sup>met\*</sup> that result in an energy defect close to 0 eV. Values of ΔE in the (-1 to +1) eV range should be considered as a valid condition for the appearance of the M-effect.

Table 1 presents the corresponding calculations of energy defect for (Kr + H<sub>2</sub>) gas mixture.

Table 1 Calculation of ΔE defect energy for (Kr + H<sub>2</sub>) gas mixture.

P <sup>+</sup> (eV)	N <sup>-</sup> (eV)	N <sup>met</sup> (eV)	P <sup>*</sup> (eV)	N (eV)	N <sup>met*</sup> (eV)	ΔE (eV)	λ (nm)
14	0.75	10.2	12.38	0	12.09	-1.02	1442.6
14	0.75	10.2	12.35	0	12.09	-0.99	1181.94
14	0.75	10.2	11.30	0	12.09	0.06	975.18
14	0.75	10.2	11.30	0	12.09	0.06	892.87
14	0.75	10.2	11.44	0	12.09	-0.08	877.67
14	0.75	10.2	12.10	0	12.09	-0.74	850.89
14	0.75	10.2	11.53	0	12.09	-0.17	829.81
14	0.75	10.2	12.14	0	12.09	-0.78	828.10
14	0.75	10.2	12.14	0	12.09	-0.78	826.32
14	0.75	10.2	11.55	0	12.09	-0.19	819.00
14	0.75	10.2	11.44	0	12.09	-0.08	811.29
14	0.75	10.2	11.44	0	12.09	-0.08	810.44
14	0.75	10.2	12.10	0	12.09	-0.74	805.95
14	0.75	10.2	11.55	0	12.09	-0.19	760.15
14	0.75	10.2	11.67	0	12.09	-0.31	<b>758.74</b>
14	0.75	10.2	12.82	0	12.09	-1.46	427.40

As it can be observed, in the particular case of the krypton-hydrogen mixture, the most possible appearance of the M-effect is represented by the 758.74 nm spectral line, but there are also other lines having very small energy defect.

## 2. Experimental set-up

The photo - view and a schematic diagram of the experimental set- up are presented in Figs. 4 and 5.

In order to allow the passage of the UV radiation, the discharge was produced in a quartz tube with 16mm inner diameter and 20mm outer diameter respectively, between two identical wolfram-thorium cylinder electrodes of 12mm diameter, spaced at 6mm distance. In front of the discharge tube was placed a reflection mirror in order to minimize the emitted radiation loss. The experimental discharge device can be pumped down up to a pressure of about 10<sup>-4</sup> mbar and then filled with various gas mixtures of spectral purity. The RF electrical power supply used in the experiment had the following characteristics: maximum output electrical tension of 2kV corresponding to a maximum electrical current intensity of 150mA, two optional frequencies of 25 kHz and 50 kHz, respectively and a filling factor of about 10-20%. The optical emission spectra of the plasma discharges were registered using an OMA (Optical Analyzer Multichannel) with a spectral range of 220-900nm, 0,5s time of integration and a

resolution of 1,5nm, after the passage of the emitted radiation through a polarization filter and a focusing lens system. The registered data are processed by means of a computer.



Fig. 4. Photo-view of the experimental set-up.

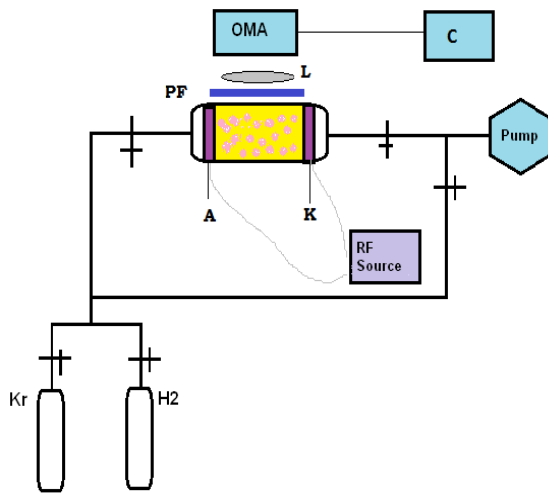

Fig. 5. Schematic diagram of the experimental device (PF- polarization filter, C- computer, L- lens, A - anode, K- cathode, OMA -Optical Multichannel Analyzer).

Some experimental data are presented in Figs 6 to 9.

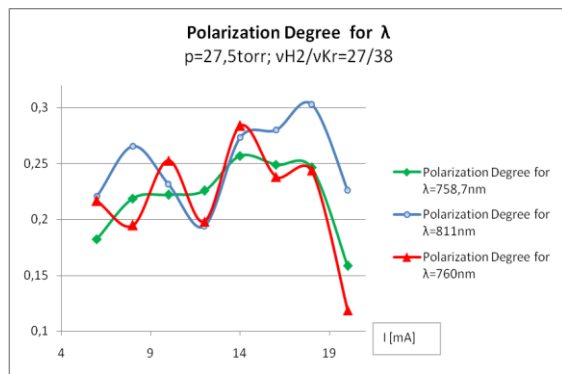

Fig. 6. Polarization Degree for  $\nu_{H_2}/\nu_{Kr}=27/38$  and  $p=27,5\text{torr}$ .

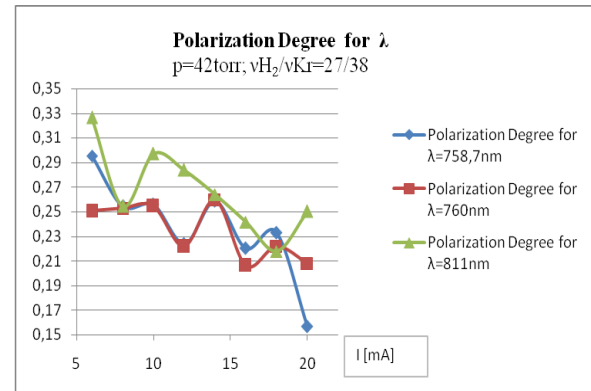

Fig. 7. Polarization Degree for  $\nu_{H_2}/\nu_{Kr}=27/38$  and  $p=42\text{torr}$ .

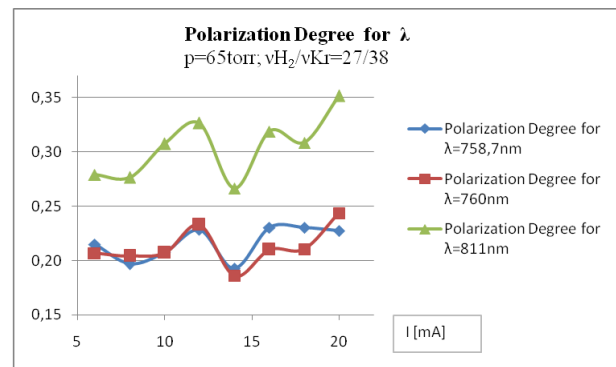

Fig. 8. Polarization Degree for  $\nu_{H_2}/\nu_{Kr}=27/38$  and  $p=65\text{torr}$ .

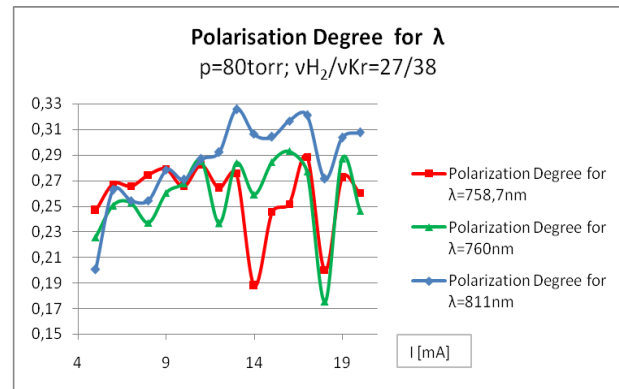

Fig. 9. Polarization Degree for  $\nu_{H_2}/\nu_{Kr}=27/38$  and  $p=80\text{torr}$ .

### 3. Results and discussion

The research model can be integrated in the statistical model ‘Analysis Of Variance (ANOVA) Two-Way’ [14], which offers the possibility to follow the evolution of a phenomenon under different conditions. In such an analysis, the following equality is true:

$$SS_t = SS_r + SS_\alpha + SS_\beta + SS_\gamma \quad (2)$$

hence the “total” variability of the data,  $SS_T$ , can be decomposed into four terms namely the variability “within cells”,  $SS_r$ , the variability “generated by the first factor”,  $SS_\alpha$ , the variability “generated by the second factor”,  $SS_\beta$ , and the variability “generated by the interaction of factors”,  $SS_\gamma$ . The following statistics have the specified Fisher distributions:

$$\frac{SS_\alpha}{SS_r}, \frac{SS_\beta}{SS_r}, \frac{SS_\gamma}{SS_r} \quad (3)$$

For the statistical analyses we have used the IBM-SPSS Trial program, version 22.0.0.

We can now construct the ANOVA table as follows:

Table 2. The PD Values for Two-Way ANOVA Method.

I Current [mA]	Polarization Degree for $\lambda=758,7\text{nm}$					Polarization Degree for $\lambda=760\text{nm}$					Polarization Degree for $\lambda=811\text{nm}$				
	p=27,5	p=42	p=65	p=80	average	p=27,5	p=42	p=65	p=80	average	p=27,5	p=42	p=65	p=80	average
6	0,18	0,30	0,21	0,27	0,24	0,22	0,25	0,21	0,25	0,23	0,22	0,33	0,28	0,26	0,27
8	0,22	0,25	0,20	0,27	0,24	0,19	0,25	0,20	0,24	0,22	0,27	0,25	0,28	0,25	0,26
10	0,22	0,26	0,21	0,27	0,24	0,25	0,25	0,21	0,27	0,25	0,23	0,30	0,31	0,27	0,28
12	0,23	0,22	0,23	0,26	0,24	0,20	0,22	0,23	0,24	0,22	0,19	0,28	0,33	0,29	0,27
14	0,26	0,26	0,19	0,19	0,22	0,28	0,26	0,19	0,26	0,25	0,27	0,26	0,27	0,31	0,28
16	0,25	0,22	0,23	0,25	0,24	0,24	0,21	0,21	0,29	0,24	0,28	0,24	0,32	0,32	0,29
18	0,25	0,23	0,23	0,20	0,23	0,24	0,22	0,21	0,18	0,21	0,30	0,22	0,31	0,27	0,28
20	0,16	0,16	0,23	0,26	0,20	0,12	0,21	0,24	0,25	0,20	0,23	0,25	0,35	0,31	0,28
average	0,22	0,24	0,22	0,25	0,23	0,22	0,23	0,21	0,25	0,23	0,25	0,27	0,30	0,29	0,28

In this study it has been analyzed the variance of the Polarization Degree (PD), for the (H<sub>2</sub>-Kr) gas mixture ( $v_{H_2}/v_{Ne}=27/38$ ) using  $I_{max}$  and  $I_{min}$ , the intensities of the dominant spectral lines ( $\lambda=758,7\text{nm}$ ,  $760\text{nm}$  and  $811\text{nm}$ ), in the following experimental conditions: different values of the discharge current, I [mA] at a constant frequency of 25 kHz for different values of the total pressure (27,5torr, 42torr, 65torr and 80torr).

The Polarization Degree (PD) was calculated using the following formula:

$$PD = \frac{I_{max} + I_{min}}{I_{max} - I_{min}} \quad (4)$$

In order to analyse the variance with repeated measurements “ANOVA two-way” - type, the goal of the research consists in polarization degree evaluation, considering the four different pressures for the three values of the spectral lines intensities (Table 3). Such a research can offer the possibility to analyze the evolution of the Polarization Degree (PD) for different values of the intensities of these chromatic lines.

Table 3. Within-Subjects Factors.

Measure: Polarization Degree		
Pressure	Wavelength	Dependent Variable
1	1	PD_wl1_p1
	2	PD_wl2_p1
	3	PD_wl3_p1
2	1	PD_wl1_p2
	2	PD_wl2_p2
	3	PD_wl3_p2
3	1	PD_wl1_p3
	2	PD_wl2_p3
	3	PD_wl3_p3
4	1	PD_wl1_p4
	2	PD_wl2_p4
	3	PD_wl3_p4

Table 4, entitled “Descriptive Statistics” shows the means and the standard deviations of the PD values, for the four values of the pressure and the three wave values of the intensities of the chromatic lines.

Table 4. Descriptive statistics.

	Mean	Std. Deviation	N
PD_wl1_p1	,21990024	,034111520	8
PD_wl2_p1	,21830320	,049865976	8
PD_wl3_p1	,24937559	,036769741	8
PD_wl1_p2	,23722546	,040485963	8
PD_wl2_p2	,23445103	,022156736	8
PD_wl3_p2	,26687151	,034238810	8
PD_wl1_p3	,21610698	,015393563	8
PD_wl2_p3	,21262757	,017813952	8
PD_wl3_p3	,30433692	,028812885	8
PD_wl1_p4	,24628152	,033139042	8
PD_wl2_p4	,24565835	,033893029	8
PD_wl3_p4	,28520281	,023400743	8

Table 5, entitled “Multivariate Tests” shows a statistically significant variation of the PD ( $p<0.01$ ), regarding the two factors (pressure and wavelength), with a high level of the effect magnitude for the wavelength factor (0,914) and a maximum observed power (1,000).

Table 5. Multivariate Tests<sup>a</sup>.

Effect		Value	F	Hypoth esis df	Error df	Sig.	Partial Eta Squared	Noncent. Parameter	Observed Power <sup>c</sup>
Pressure	Pillai's Trace	,430	1,260 <sup>b</sup>	3,000	5,000	,382	,430	3,780	,183
	Wilks' Lambda	,570	1,260 <sup>b</sup>	3,000	5,000	,382	,430	3,780	,183
	Hotelling's Trace	,756	1,260 <sup>b</sup>	3,000	5,000	,382	,430	3,780	,183
	Roy's Largest Root	,756	1,260 <sup>b</sup>	3,000	5,000	,382	,430	3,780	,183
Wavelength	Pillai's Trace	,914	31,849 <sup>b</sup>	2,000	6,000	,001	,914	63,697	1,000
	Wilks' Lambda	,086	31,849 <sup>b</sup>	2,000	6,000	,001	,914	63,697	1,000
	Hotelling's Trace	10,616	31,849 <sup>b</sup>	2,000	6,000	,001	,914	63,697	1,000
	Roy's Largest Root	10,616	31,849 <sup>b</sup>	2,000	6,000	,001	,914	63,697	1,000
Pressure * Wavelength	Pillai's Trace	,961	8,253 <sup>b</sup>	6,000	2,000	,112	,961	49,517	,376
	Wilks' Lambda	,039	8,253 <sup>b</sup>	6,000	2,000	,112	,961	49,517	,376
	Hotelling's Trace	24,759	8,253 <sup>b</sup>	6,000	2,000	,112	,961	49,517	,376
	Roy's Largest Root	24,759	8,253 <sup>b</sup>	6,000	2,000	,112	,961	49,517	,376
a. Design: Intercept									
Within Subjects Design: Pressure + Wavelength + Pressure * Wavelength									
b. Exact statistic									
c. Computed using alpha = ,05									

If we use the univariate tests, we have to analyze first the Mauchly Test for the sphericity, which is significant for the two above-mentioned factors, namely the pressure and the wavelength, respectively (Table 6).

Table 6. Mauchly's Test of Sphericity<sup>a</sup>.

Measure: PolarizationDegree							
Within Subjects Effect	Mauchly's W	Approx. Chi-Square	df	Sig.	Epsilon <sup>b</sup>		
					Greenhouse-Geisser	Huynh-Feldt	Lower-bound
Pressure	<b>.471</b>	4,304	5	.512	.735	1,000	.333
WaveLength	<b>.902</b>	.618	2	.734	.911	1,000	.500
Pressure * WaveLength	.016	19,756	20	.580	.560	1,000	.167

Tests the null hypothesis that the error covariance matrix of the orthonormalized transformed dependent variables is proportional to an identity matrix.  
 a. Design: Intercept  
 Within Subjects Design: Pressure + WaveLength + Pressure \* WaveLength  
 b. May be used to adjust the degrees of freedom for the averaged tests of significance. Corrected tests are displayed in the Tests of Within-Subjects Effects table.

Because the Mauchly test was significant, we have used the Greenhouse-Geisser correction. As it is shown in the Table 7, both the main effects of the two factors and their interaction were statistically significant. This means that the values of the PD vary with the pressure, the wavelength and also with the effect of the two factors interaction.

Table 7. Tests of Within-Subjects Effects.

Measure: PolarizationDegree									
Source		Type III Sum of Squares	df	Mean Square	F	Sig.	Partial Eta Squared	Noncent. Parameter	Observed Power <sup>a</sup>
Pressure	Sphericity Assumed	.011	3	.004	1,409	.268	.168	4,228	.319
	Greenhouse-Geisser	.011	2,2	.005	1,409	.276	.168	3,106	.266
	Huynh-Feldt	.011	3,0	.004	1,409	.268	.168	4,228	.319
	Lower-bound	.011	1,0	.011	1,409	.274	.168	1,409	.178
Error (Pressure)	Sphericity Assumed	.053	21	.003					
	Greenhouse-Geisser	.053	15,4	.003					
	Huynh-Feldt	.053	21,00	.003					
	Lower-bound	.053	7,00	.008					
WaveLength	Sphericity Assumed	.048	2	.024	47,87	.000	.872	95,73	1,000
	Greenhouse-Geisser	.048	1,82	.027	47,87	.000	.872	87,19	1,000
	Huynh-Feldt	.048	2,00	.024	47,87	.000	.872	95,73	1,000
	Lower-bound	.048	1,00	.048	47,87	.000	.872	47,87	1,000
Error (WaveLength)	Sphericity Assumed	.007	14	.001					
	Greenhouse-Geisser	.007	12,8	.001					
	Huynh-Feldt	.007	14,00	.001					
	Lower-bound	.007	7,00	.001					
Pressure * WaveLength	Sphericity Assumed	.013	6	.002	4,368	.002	.384	26,21	.965
	Greenhouse-Geisser	.013	3,36	.004	4,368	.012	.384	14,67	.835
	Huynh-Feldt	.013	6,00	.002	4,368	.002	.384	26,21	.965
	Lower-bound	.013	1,00	.013	4,368	.075	.384	4,368	.438
Error (Pressure * WaveLength)	Sphericity Assumed	.021	42	.000					
	Greenhouse-Geisser	.021	23,52	.001					
	Huynh-Feldt	.021	42,00	.000					
	Lower-bound	.021	7,00	.003					

a. Computed using alpha = .05

The post-hoc test of the multiple comparisons for the wavelengths shows the existence of a statistically significant difference between the values of the intensities of the chromatic lines,  $\lambda=578,7\text{nm}$  and  $\lambda=811\text{nm}$  (Table 8).

Table 8. Pairwise Comparisons.

Measure: PolarizationDegree						
(I) WaveLength	(J) Wave Length	Mean Difference (I-J)	Std. Error	Sig. <sup>b</sup>	95% Confidence Interval for Difference <sup>b</sup>	
					Lower Bound	Upper Bound
1	2	.002	.005	1,00	-.013	.017
	3	-.047 <sup>*</sup>	.006	.000	-.066	-.027
2	1	-.002	.005	1,00	-.017	.013
	3	-.049 <sup>*</sup>	.006	.000	-.067	-.030
3	1	.047 <sup>*</sup>	.006	.000	.027	.066
	2	.049 <sup>*</sup>	.006	.000	.030	.067

Based on estimated marginal means  
 \*. The mean difference is significant at the .05 level.  
 b. Adjustment for multiple comparisons: Bonferroni.

Fig. 10 presents the variation form of the Marginal Means of PD for the two factors (pressure and wavelength of the intensities of the chromatic lines), considering the four values of the gas mixture total pressure.

For the first and the second wavelength (758,7nm, 760nm, respectively), the global variation of PD increases from the pressure of 27,5torr to the pressure of 42torr and from the pressure of 65torr to the pressure of 80torr, but decreases from the pressure p = 42torr to the pressure 65torr. For the third wavelength of the intensities of the chromatic lines ( $\lambda=811\text{nm}$ ), the global variation of PD increases progressively from the pressure of 27,5torr to the pressure of 65torr and then decreases to the pressure of 80 torr.

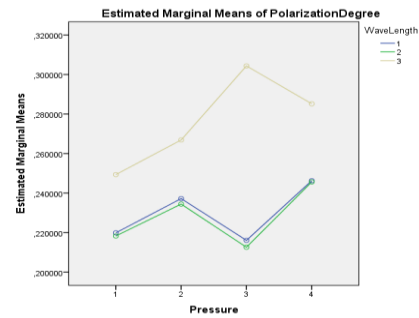

Fig. 10. The variance of PD depending on pressure for three wavelengths of the intensities of the chromatic lines.

#### 4. Conclusion

The goal of this paper was the statistical analysis of Polarization Degree of Chromatic Lines in H<sub>2</sub>-Kr Gas Mixture, considering four different pressures (27,5torr, 42torr, 65torr and 80torr) for three values of the intensities of the chromatic lines (758,7nm, 760nm and 811nm).

A preliminary conclusion of this study is the fact that the polarization degree of the dominant spectral lines depends on the total pressure of the gas mixture in the same way as the monochromatization - effect, which is strongly dependent of the pressure increase, because the main mechanism of its generation is a three-body reaction.

However, further researches must be performed in order to clarify the basic phenomena which appear during the polarization process.

### References

- [1] G. Musa, A. Popescu, A. Baltog, C. P. Lungu, *Romanian Reports in Physics (review paper)* **45**, 287 (1993).
- [2] S. D. Popa, P. Chiru, L. Ciobotaru, *Journal of Physics D: Applied Physics*, **31**(15), L53 (1998).
- [3] L. C. Ciobotaru, S. D. Popa, DOI:10.1016/j.vacuum.2014.06.003, *VACUUM*, 2014.
- [4] L. C. Ciobotaru, *Proceedings of The 8-th International Symposium on Applied Plasma Science (ISAPS)*, 78 - 42, Hakone, Japan, 2011, ISBN-978-4-9900642-7-3.
- [5] L. Landau, *Phys., Z. Sowjet*, **46**, 221 (1932).
- [6] C. Zener, *Proceedings of Royal Society A*, 137, 696, 1932.
- [7] R. Vladioiu, M. Contulov, A. Mandes, G. Musa, *European Physical Journal D*, **54**(2), 287 (2009).
- [8] R. Vladioiu, M. Contulov, V. Ciupina, G. Musa, *Contributions to Plasma Physics*, **50**(2), 177 (2010).
- [9] L. C. Ciobotaru, *Optoelectron. Adv. Mater. Rapid Commun.* **6**(5-6), 668 (2012).
- [10] L. C. Ciobotaru, *Optoelectron. Adv. Mater. Rapid Commun.*, **5**(3), 327 (2011).
- [11] L. C. Ciobotaru, *Romanian Reports in Physics*, **62**(1), 134 (2010).
- [12] L. C. Ciobotaru, *Romanian Reports in Physics*, **61**(1), 53 (2009).
- [13] L. C. Ciobotaru, G. Musa, *Turkish Journal of Physics*, **36**(1), 77 (2012).
- [14] C. C. Surdu-Bob, G. Musa, *J. Phys. D: Appl. Phys.* **41**, 172004 (2008).
- [15] M. Dumitrescu, A. Batatorescu, *Applied Statistics*, Ed Univ Bucharest, 2006, ISBN 937-737-119-4.
- [16] C. C. Surdu-Bob, P. M. Racolta, M. Badulescu, C. Chiojdeanu, N. Arsene, C. Logofatu, C. Ionescu, D. Sporea, I. Gruia, *Optoelectron. Adv. Mater. -Rapid Comm.* **5**(12), 1336 (2011).
- [17] M. Badulescu, I. Gruia, C. Surdu-Bob, C. Iacob, *Optoelectron. Adv. Mater. -Rapid Comm.* **3**(12), 1269 (2009).
- [18] M. Badulescu, I. Gruia, C. Surdu-Bob, C. Iacob, *Optoelectron. Adv. Mater. -Rapid Comm.* **3**(11), 1231 (2009).
- [19] M. Badulescu, I. Gruia, V. Micheli, L. Calliari, C. Surdu-Bob, *Optoelectron. Adv. Mater. -Rapid Comm.* **3**(11), 1207 (2009).

---

\*Corresponding author: gruia\_ion@yahoo.com