

Design of a surface acoustic wave sensors array

H. PAIS, C. GRIGORIU^a, C. VIESPE^{a,*}

S.C. PRO ENGINEERING S.R.L, 022183 Bucharest, Romania

^aNational Institute of Laser, Plasma and Radiation Physics, 077125 Bucharest, Romania

A surface acoustic wave sensors array was developed, with the final aim of use as a detector for gases. The elementary sensors are of the “delay line” type, with a central frequency of ~69.5 MHz. To allow detection and recognition of different gases and to compensate for environment effects, a modular solution with an array of eight sensors was chosen. This system allows measurement by up to four sensors simultaneously, with the other four acting as reference sensors, or up to seven sensors with a single sensor used as reference sensor.

(Received June 19, 2012; accepted October 30, 2012)

Keywords: SAW sensor, Array sensors, Gas detector

1. Introduction

In this paper, the design of an array of Surface Acoustic Wave Sensors (SAWS) is presented. The elementary sensor generally consists of a piezoelectric substrate, a pair of interdigital transducers, and an ad/absorbent film. The electrical signal connected to one of the transducers generates a surface acoustic wave that propagates toward the other transducer. The mechanical wave is then converted into an electrical signal. The sensing mechanism involves physico-chemical interaction between the sensitive layer and the analyte gas. The sensor was presented in our previous work [1-4].

To allow identification of different gases, we developed an array of sensors with different sensitive layers, each having a different response to different gases. By correlating the results, a specific algorithm developed by us [5] allowed gas detection with a probability that increased with the number of sensors.

Due to their compact structure, small size, low cost, high sensitivity, and fast response, portable systems of this type are recommended for detecting chemical warfare agents [6-8].

Development of a sensor must consider external interfering factors. The most significant environmental factor that disturbs sensor performance is temperature, which principally affects the substrate material (for example, for a substrate material of Y-cut LiNbO₃ with propagation in the Z direction, the change in sensitivity is approximately 80 ppm/^oC). The temperature can also have a considerable influence on film viscosity, stiffness, and volume, resulting in different sensitivities and response times for different sensors [9-10]. Another environmental factor that affects the coating material is humidity. This has an important influence on the surface acoustic wave attenuation and velocity [10-13]. To compensate for environmental effects, one sensor was used as a reference. Each sensor response is represented by the difference between the frequency shift of the sensor and the

frequency shift of the reference sensor.

The sensor array had eight channels, allowing us to use eight sensors simultaneously. We could choose between two configurations: four sensors with different sensitive layers correlated with four sensors used as reference sensor (individual compensation) or a maximum of seven sensors in a configuration with a single reference (common compensation). The block diagram was designed to allow a choice between two compensation types:

1) individual compensation for each sensor type, with a sensor reference made using the same technology and deposited on the same sensitive layer, but unaffected by the sample gas;

2) common compensation, with a single reference sensors chosen as a common reference without a sensitive layer.

The first solution allows us to minimise the effect of temperature and humidity on the sensitive layer and quartz substrate. In the second case, only the effect of temperature on the quartz substrate is eliminated, but we can use more sensors than in the first case, with different responses to the target gases and higher probability of correct gas identification.

A modular configuration was chosen that performs the following functions:

- simultaneous eight-channel frequency measurement;
- direct measurement of the frequency: the frequency of each channel divided by 4 is directly measured for a period of 4 seconds, resulting a measurement resolution of 1 Hz;
- serial transmission of data read from the transducers, according to an ASCII protocol with checksum for all eight channels every 4 seconds;
- local display of the measured frequencies in two modes: eight-channel mode scroll or two channels in selection mode. Local display mode does not affect the transmitted serial data.

2. Method

The block diagram of the electronic circuit that permits simultaneously measurement of eight transducers is presented in Fig. 1.

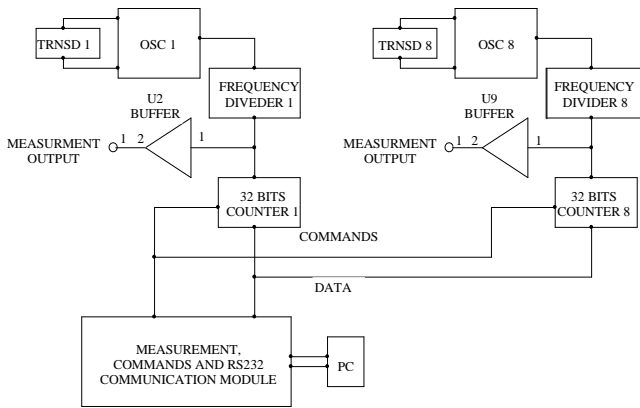

Fig. 1. Block diagram of electronic circuit.

From the construction point of view, the system is organised as follows:

- eight adapter modules for SAWS (including the circuit for frequency measurement).
- a control module, for measurement and communication (including connectors and connector-adaptor modules for the local display module).
- a local display module that includes a keyboard with four keys for mode selection of the local display.

The printed circuit boards for adapter modules were made using double-plated circuit layers of 0.8-mm thickness, to achieve 50 Ω impedance for specific electrical traces. The design of individual modules was made taking into account the operating conditions of an ensemble of eight oscillators working at slightly different frequencies. To decrease the influence between modules, electromagnetic shields were used between the frequency-oscillator and frequency-divider stages. For the command and display module, double-plated 1.6-mm printed circuit board was used.

Oscillator

For stable oscillation to occur, the signal has to add coherently to itself after having traversed the loop; it must return to its starting point with equal amplitude after a phase shift by an integral multiple of 2π radians. These conditions are simultaneously satisfied at the frequencies where the gain of the particular amplifier is greater than or equal to the insertion loss, and the phase shift is zero [14]. When the loop has several frequencies for which the phase conditions are satisfied, it becomes difficult to say at which frequency the oscillation will be stabilised. A commonly used method is to selectively filter the output voltage of the amplifier loop around the desired oscillation

frequency. The elementary sensors have a strong capacitive behaviour. For use in oscillation schemes, it is necessary to offset this effect by adding inductive elements at both ports. The result obtained is shown in Fig. 2.

As can be seen, the insertion loss of the compensated transducer is about 19 dB, and the side lobes are sufficiently attenuated (-42 dB). The oscillation frequency is always set to the main lobe value without additional filtering. Essentially, the selective nature of the sensor determines the oscillator frequency.

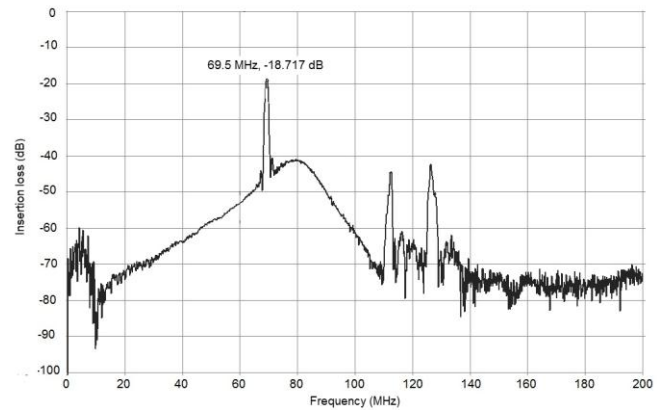

Fig. 2. Insertion loss-compensated SAW transducer assembly at both test ports.

The main element of any oscillator is the amplifier that provides gain. An amplifier may consist of discrete components or an integrated RF amplifier. It is preferable to use a monolithic integrated amplifier due to advantages such as the following:

- a wide range of models with parameters adapted to various applications;
- special design for operation adapted to the impedance of 50 Ω ;
- repeatability of parameters provided by the manufacturer.

Amplification is the main selection parameter because it should be sufficient to compensate all losses in the oscillation loop at the desired frequency response.

To allow rapid oscillation initialisation, a reserve of 6 dB gain was considered sufficient. Considering the typical attenuation of a surface-wave delay line of between 15 and 20 dB, the loss of 1–2 dB due to coupling circuits, and losses of 1–2 dB due to the impedance mismatch, the 6-dB gain reserve results in amplification of about 25 dB at the operating frequency. Due to changes in sensor parameters arising from modifications to the sensitive layer during gas ad/absorption analysis, an additional loss of 3 dB may occur.

The maximum output power is another criterion that should be considered when using amplifiers with high gain associated with the maximum power applied at input. Operation must be reliable even when power losses are minimal in the feedback loop.

Taking into account the above conditions, the amplifier model MAR-8A from the Mini-Circuits Company was chosen. It has the following main parameters:

- gain: 31.5 dB typically, 30 dB minimum at 0.1 GHz;
- frequency range: DC – 1000 MHz;
- typical output power of +12.5 dBm;
- maximum input power: 13 dBm (high maximum power output);
- power supply: 3.7 V / 36 mA.

An electric diagram of the oscillator is shown in Fig. 3.

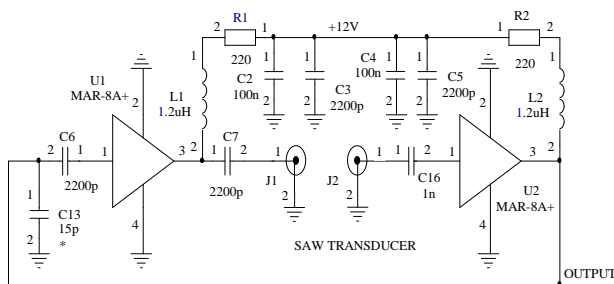

Fig. 3. The oscillator circuit.

The sizing of decoupling capacities HF (C3, C5) and coupling (C6, C7, and C16) was made by considering their impedance at the operating frequency to be below 0.5 ohm.

Amplifier U2 (part of the main amplifier) also ensured SAWS separation from the next stage (frequency divided by 4) and a proper level of the signal corresponding to the input-frequency divider.

Frequency divider

Because the maximum working frequency of the counting circuit at 32 bits is 25 MHz, and our sensors oscillate at ~70 MHz, it was necessary to have a frequency divider.

This was made with a dedicated circuit (PE3512 type) from the Peregrine Semiconductors Company, which had the following main parameters:

- frequency range: DC – 1500 MHz;
- RF input signal or LV (CMOS);
- RF input power: -10 ... 10 dBm (DC ... 1000 MHz);
- CMOS-compatible outputs;
- power supply: 3 Vcc.

Buffer stage

To enable the direct measurement of the frequency of each oscillator part (divided by 4), a buffer stage was designed with a high-speed LT1720A-type comparator. It had the following main parameters:

- response time: 4.5 ns with 20-mV differential input signal;

- 3 and 5 V operation optimised;
- TTL-compatible outputs / CMOS;
- power supply of 2.7–6 V.

The 32-bit counting circuit

The 32-bit counting circuit was made using the CMOS SN74LV8154D from Texas Instruments, with a maximum input frequency of 25 MHz. The logic of the measurement signals was provided by the control board via two-input NAND selection circuits.

The power supply system

It was decided to separate the digital circuits from the RF circuit supply. An external regulated power supply was chosen that could supply 15–Vdc at a current of 2 A. Decoupling circuits were provided for each active device to minimise the possibility of the penetration of high-frequency components in the power circuits.

The supply scheme provides the following voltages:

- for each block of the voltage oscillator from 15 to 18 Vdc, the 12 Vcc local voltage is obtained for RF stages;
- for the measurement and control modules, a regulated voltage of 3.3 V / 0.8 A was used for all digital circuitry (except the frequency divider);
- for each oscillating block, a 3 Vdc voltage was required by the frequency divider.

Measurement and communication module

The block diagram of this module is shown in Fig. 4.

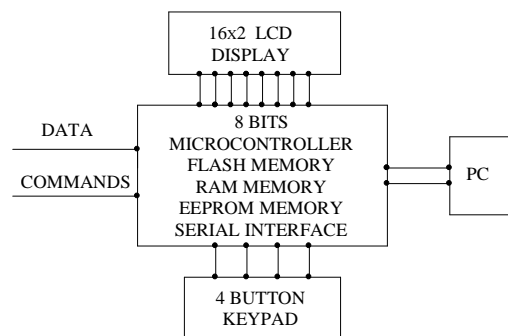

Fig. 4. Block diagram of the measurement and communication module.

Due to the distribution of the counting circuits on the modules adapters, the design of the measurement and communication module was simplified. For measuring frequencies with 1-Hz resolution, a method for counting periods of the signal in a time window of 4 s was used (the measured frequency was divided by 4). The counting capacity is 32 bits, ensuring that up to 4,294,967,296 pulses can be counted. Taking into consideration the maximum clock frequency of the counters, the maximum measured frequency can reach about 100 MHz (25 MHz × 4).

The control signals assure the synchronisation of all eight channels, clear them for new counting, and assure the transfer of data to the microcontroller. Because the

counting circuits are provided with buffer registers, the transfer of counter records in buffer registers is made for all eight channels simultaneously. The transfer is made on an octet basis, in sequential mode, for all eight channels.

The control element is a microcontroller. An AVR microcontroller produced by the ATMEL Company was selected (model ATMEGA32). It has all the necessary internal resources for coordinating the system, including the following:

- 32-Kb flash memory in-system programmable instruction;
- 1-Kb EEPROM non-volatile memory for storing settings;
- 2 Kb of RAM for data processing;
- an on-chip quartz oscillator;
- timer circuits to obtain precise timing;
- I/O port pins for executing commands and reading data;
- a fully programmable serial interface for communication with other systems (the PC).

Level conversion for standard RS232 was achieved in the measurement and communication module and ensures exchange of data with the calculation system.

3. Conclusion

An array of SAWS was successfully designed and implemented for detection of gases. The design of the electronic system gave us the possibility of using eight sensors simultaneously: seven elementary sensors in a configuration with a single reference sensor or four elementary sensors, each with a reference made under the same conditions but unaffected by the target gases. For measuring frequencies at 1-Hz resolution, a method for counting the periods of the signal in a time window of 4 s was used (the measured frequency was divided by 4).

Acknowledgement

This work was supported by two grants of the Romanian National Authority for Scientific Research, CNCS – UEFISCDI project number PN-II-RU-PD-2011-3-0141 and CNDI – UEFISCDI project number 107/2012.

References

- [1] C. Viespe, C. Grigoriu, C. Toader, I. M. Popescu, University Politehnica of Bucharest Scientific Bulletin-Series A-Applied Mathematics and Physics, **73**, 195 (2011).
- [2] I. Nicolae, C. Viespe, C. Grigoriu, Sens. Actuators B, **158**, 418 (2011).
- [3] C. Viespe, C. Grigoriu, Sens. Actuators B, **147**, 43 (2010).
- [4] C. Viespe, C. Grigoriu, C. Toader, N. Grigoriu IEEE CAS 2009 Proceedings, 263 (2009).
- [5] I. Bucur, S. Serban, A. Surpateanu, N. Cupcea, C. Viespe, C. Grigoriu, C. Toader, N. Grigoriu IEEE CAS Proceedings, 209 (2010).
- [6] T. Alizadeh, S. Zeynali, Sens. Actuators B **129**, 412 (2008).
- [7] D. Matatagui, J. Marti, M. J. Fernandez, J. L. Fontecha, J. Guutierrez, I. Gracia, C. Cane, M. C. Horrillo, Sens. Actuators B **154**, 199 (2011).
- [8] D. Matatagui, J. Marti, M. J. Fernandez, J. L. Fontecha, J. Guutierrez, I. Gracia, C. Cane, M. C. Horrillo, Procedia Chemistry **1**, 232 (2009).
- [9] M. Thomson, D. C. Stone, John Wiley & Sons, Inc, **144**, 74 (1997).
- [10] Edward T. Zellers, Mingwei Han, Anal. Chem., **68**(14), 2409 (1996).
- [11] R. Rimeika, R. Rotomskis, V. Poderys, D. Čiplys, A. Sereika, M. S. Shur, ULTRAGARSAS (ULTRASOUND), **63**(3) 1392 (2008).
- [12] S. Nomura, T. Yasuda, T. Furukawa, Ultrasonics Symposium, Proceedings IEEE, **1**, 417 (1993).
- [13] C. Caliendo, E. Verona, A. D'Amico, A. Furlani, G. Iucci, M. V. Russo, Sensors and Actuators B. Chemical, **16**, 288 (1993).
- [14] D. S. Ballatine, R. M. White, S. J. Martin, A. J. Rico, E. T. Zellers, G. C. Frye, H. Wohltjen, Acoustic Wave Sensors, Academic Press, San Diego, 368 (1997).

*Corresponding author: viespe@ifin.nipne.ro