

Detection of tea concentration macerated onto the artificial teeth using fiber optic displacement sensor

M. YASIN*, S. W. HARUN^a, R. APSARI, SUHARININGSIH, KUSMINARTO^b, KARYONO^b, H. AHMAD^c

Department of Physics, Faculty of Science and Technology, Airlangga University, 60115 Surabaya, Indonesia

^aDepartment of Electrical Engineering, Faculty of Engineering, University of Malaya, 50603 Kuala Lumpur, Malaysia

^bDepartment of Physics, Faculty of Mathematics and Natural Science, Gadjah Mada University, 55281 Yogyakarta, Indonesia

^cPhotonics Research Centre, Department of Physics, Faculty of Science, University of Malaya, 50603 Kuala Lumpur, Malaysia

The performance of fiber-optic displacement sensor, which uses artificial teeth as a target is demonstrated for various tea concentration macerated onto the target. In the experiment, a concentric type of bundled fiber and yellow He-Ne laser are used as a probe and a light source, respectively. The location of peak voltage shifts to a shorter displacement as the tea concentration increases. The sensitivity of both slopes are also reduced with the increment of tea concentration. This is attributed to the reduction of the received light intensity because of the change of the refractive index at the teeth surface, which actually changes the angle of the reflected light beam. The stability of the sensor, a high sensitivity and the simplicity of the design, low cost of fabrication make it suitable for chemical, biomedical, pharmaceutical and process control applications.

(Received January 16, 2010; accepted February 02, 2010)

Keywords: Fiber-optic displacement sensor, Artificial teeth sample, Tea concentration

1. Introduction

Optical fiber sensors possess a number of advantages over conventional electrical sensing technologies, which make them attractive for a wide range of application areas. These advantages include intrinsic safety in chemically hostile or explosive environments, low susceptibility to electromagnetic interference, electrically passive operation, high sensitivity, compatible with composites, light weight and geometrical versatility. These sensors have been used in various branches of science and engineering, as is evident from a vast range of properties which has been sensed optically, ranging from light intensity, vibration, temperature, pressure, strain, liquid level, pH, chemical analysis, concentration, density, refractive index of liquids, teeth colorimeter and etc [1–6].

Color is a visible perception and dependent on three elements: (1) illumination (spectrum energy distribution); (2) absorbance and scattering of illuminated object; (3) observer (spectral response related to wavelength). It is very difficult to determine the color of some objects accurately, such as human teeth that have many undesirable properties, for example, the surface roughness and inhomogeneity of intrinsic materials among other persons. In clinical works, the tooth color determination was mainly affected by the environmental factors, for instance, the interference of indoor lightness. However, the variation of the color perception of dentists is easily ignored. It is very important to match the teeth color more objectively and accurately in dental clinical works, and to enable the effective and consistent communication with dental technicians. In addition, dental laboratories admit to

a 6 percent remake rate annually. Half of these remakes (3 percent) occur for misinterpretation and failure to match shades accurately. Consequently in clinics, the needs for more reliable and reproducible determination of teeth color has become more significantly. In this paper, colorimeter system is demonstrated for an artificial teeth based on detection of reflected beam using fiber bundled displacement sensor with intensity modulation technique. The effect of tea concentration on the displacement curve is investigated.

2. Experimental setup

Fig. 1 shows the schematic diagram of experimental set-up for the fiber-optic sensor to differentiate various tea concentrations on the macerated teeth. The set-up consists of a fiber optic transmitter and receiver, fiber optic probe, flat teeth surface, silicon photo-detector, and computer. A plastic optical fiber (POF) bundled probe is used together with yellow He-Ne laser due to its low cost and high reliability. The bundled POF is 2 m long with numerical aperture of 0.5 and consists of one transmitting core with diameter of 1.00mm and 16 receiving cores with diameter of 0.25mm. A silicon photo-detector with an effective area of 1cm² is used to ensure efficient optical directional coupling with the receiving fiber. The detector also has a fast response time, which is suitable for high speed digital data links. The chopper is used in conjunction with lock in amplifier for the detection system to reduce the dc drift voltage due to an ambient light.

The displacement of the fiber optic probe is achieved by mounting it on a micro displacement meter, which is rigidly attached to a vibration free table. Light from the fiber optic transmitter (peak wavelength at 594 nm) is coupled into the transmitting fiber. The signal from the receiving fiber is measured by moving the probe away from the zero point, where the reflective surface of teeth samples and the probe are in close contact. The signal from the detector is converted to voltage and is measured by a lock-in amplifier and computer via RS232 using a

Delphi software. The object is teeth sample which is macerated for 30 hours in various tea concentrations from 0 to 10%. The output intensity is measured by changing the position of the fiber optic probe from 0 to 3 mm in a step of 15 μm (500 positive pulses of the piezoelectric stage). The measurements are carried out for tea solutions with concentrations of 0, 2, 6 and 10%. During the experiment, the temperature is kept constant and the error due to this temperature variation is negligible.

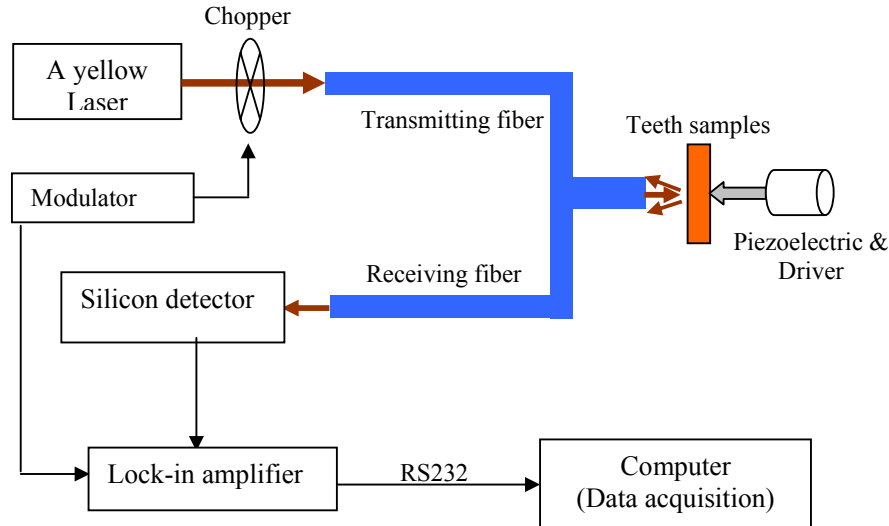

Fig.1. Schematic diagram of fiber optic displacement for detection of reflected beam from an artificial teeth sample.

3. Results and discussion

Fig. 2 shows the displacement curve generated in the receiving fiber for various percentages of tea concentration. All curves exhibit a maximum with a linear step of the front slope while the back slope follows an almost inverse square law relationship. At small displacement, the output voltage increases with the displacement, which increases the overlapping between the transmitted and received lights cone. After reaching the maximum, the output voltage starts to decrease with displacement due to large increase in the size of the light cone as the power density decreases with increase in the size of the cone of light. The similar trend has been obtained in the previous works using other objects such as flat mirror and metal [7-8]. As shown in Fig. 2, the maximum peak shifts to a shorter distance as the tea concentration increases. This is due to the deterioration of the mode coupling efficiency with the increase of concentration. The reduction of the received light intensity is due to the change of the refractive index at the teeth surface, which actually changes the angle of the reflected light beam.

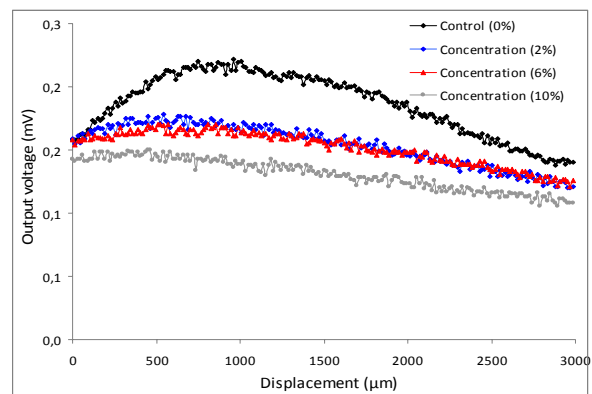

Fig. 2. The output voltage as function of artificial teeth displacement for various tea concentration.

The sensitivity and linear range of both slopes in Fig. 2 is then measured and the results are summarized in Table 1. From these results, it is observed that the highest sensitivity of $0.0001\text{mV}/\mu\text{m}$ is achieved for a concentration of 0% and the lowest sensitivity is obtained at 10%.

This shows that tea concentration reduces the intensity of the light beam reflected from the teeth surface. On the other hand, the linear range is observed to random for different tea concentration. The highest linear range of 1290 μm is obtained at back slope for a concentration of 0%. Based on these results, it is found that the tea

concentration affects reflectivity of artificial teeth, then the sensitivity and the location of maximum intensity of the sensor are changed. This finding may be quite useful for chemical, pharmaceutical, biomedical and process control sensing applications.

Table 1. The performance of the displacement sensor for teeth samples.

Tea concentration (%)	Front slope		Back slope	
	Sensitivity (mV/ μm)	linear range (μm)	Sensitivity (mV/ μm)	linear range (μm)
0	0.00010	480 (75-555)	0.00005	1290 (1485-2775)
2	0.00007	105 (75-180)	0.00002	1080 (855-1935)
6	0.00002	405 (30-435)	0.00002	840 (1080-1920)
10	0.00002	180 (30-210)	0.00002	1080 (645-1725)

4. Conclusions

Fiber optic displacement sensor is demonstrated using a tea macerated artificial teeth as a target. The effect of tea concentrations on the displacement curve is investigated. As the concentration of tea increases, the location of peak voltage shifts to a shorter displacement and the received light intensity reduces. The sensitivity of both slopes are also reduces with the increment of tea concentration. This is attributed to the reduction of the received light intensity because of the change of the refractive index at the teeth surface, which actually changes the angle of the reflected light beam. The sensitivities of 0.00010mV/ μm and 0.00002mV/ μm are obtained at tea concentration of 0% and 10% respectively.

References

- [1] S. Binu, V. P. Mahadevan Pillai, N. Chandrasekaran, *Optics & Laser Technology* **39**, 1537 (2007).

- [2] W. C. Michie, B. Culshaw, I. McKenzie, M. Konstantakis, *Optics Letters* **20**, 103 (1995).
 [3] S. Binu, V. P. Mahadevan Pillai, V. Pradeepkumar, B. B. Padhy, C. S. Joseph, N. Chandrasekaran, *Materials Science and Engineering C* **29**, 83 (2009).
 [4] S. Binu, V. P. Mahadevan Pillai, N. Chanrasekaran, *Opt. Quantum Electron* **39**, 747 (2007).
 [5] S. Yu, C. H. Chen, H. K. Chang, *Biomedical Engineering-App., Basis & Comm.* **16**, 73 (2004).
 [6] J. J. ten Bosch, J. C. Coops, *J. Dent Res.* **74**, 374 (1995).
 [7] M. Yasin, S. W. Harun, Samian, Kusminarto, H. Ahmad, *Laser Physics* **19**, 1446 (2009).
 [8] M. Yasin, S. W. Harun, H. A. Abdul-Rashid, Kusminarto, Karyono, H. Ahmad, *Laser Physics Letters* **5**, 55 (2008).

*Corresponding authors: yasin@unair.ac.id