

Extended spectral range laser receiver

M. JURBA*, E. POPESCU, S. COJOCARU, D. GUIMAN, D. STROE
Electro Optic Systems M.C. S.R.L., Bucuresti, Romania

Laser Warning Systems (LWS) are devices designed to ensure protection of different kind of land or sea vehicles or even stationary installations or buildings against laser associated weapon threats. A key component of this system is represented by the laser receiver. Laser receivers are integrated in one or more laser heads mounted on the objective which has to be protected. Each laser receiver covers a field of view, which represents the angular resolution of the system. The present paper presents a laser receiver configuration which allows an extended spectral range covering all the existent laser threats, and also allows a good discrimination between detection of direct and reflected laser beams.

(Received September 4, 2012; accepted October 30, 2012)

Keywords: Laser Warning Systems (LWS), Laser wavelength, PIN photodiode

1. Introduction

The laser warning systems (LWS) are designed to detect incident laser irradiation on special vehicles, strategic installations and constructions.

The LWS system generates a warning signal for counter-measures. It's purpose is to reduce the vulnerability to the numerous laser associated weapon threats by providing an early warning signal that informs a crew or specially trained persons about a possible threat. The system displays also the type of threat and direction of irradiation [1].

The operator of the system can then take appropriate self-protective action such as deployment of a smoke, water-fog screen or vehicle maneuver.

The laser warning systems are designed to be used on all kinds of land, sea or transport vehicles. It can also be integrated into protection systems of stationary installations, buildings etc. These systems must be capable of detecting a number of laser sources of various types of threatening in a wide range of the IR and visual spectrum.

Other requirement of the laser warning systems is to be reliable, flexible, suitable for integration into any

protection system. The integration level may vary from stand-alone solutions that include complete threat indication and alarm capability to fully integrated solutions with alarm indications on LCD panels or screens of other systems including automated activation of counter-actions.

2. LWS Requirements

Laser warning systems must meet a number of technical requirements [2]. Between these requirements the most important are:

1. Detection of different Laser Threats

LWS must be capable of detecting all types of lasers pulsed or modulated continuous wave and discriminate them from the background and any other light source. The types of lasers used in such applications and their wavelength are presented in the Table 1:

Table 1.

Laser type	Wavelength	Impulse power
Frequency doubled Nd:YAG	wavelength $\lambda=532$ nm	1÷3 MW
Ruby laser	wavelength $\lambda=694.3$ nm	0.8÷1.5 MW
InGaAs laser diodes	wavelength $\lambda=905$ nm	50÷100 W
Nd:YAG, Nd:Glass	wavelength $\lambda=1064$ nm	1÷3 MW
Er:Glass	wavelength $\lambda=1540$ nm	0.2÷0.5 MW
Raman shifted Nd:YAG	wavelength $\lambda=1550$ nm	0.25÷1 MW

2. Identify type of incoming threat:

Identifying the type of laser threat type is very important and that can be done by measuring its

parameters and comparing them with an internal database. The most important laser threats are:

- Laser Range Finders

- Laser Designators
- Laser Beam Riders
- Other Laser Sources (blinding laser weapons)

3. Identify the direction of laser threat

It is very important to determine the direction of laser threat with a reasonable resolution in order to launch the counter-measure in the right direction. A reasonable resolution in detecting direction of laser threat is of $\pm 15^\circ$. A higher accuracy has rather commercial value, as the counter-measures are designed to cover much higher angles.

4. Reject reflected beam

As the divergence of most laser systems is of about 1 mrad, at distances of a few kilometers the dimension of laser beam is comparable with the size of the irradiated vehicle. On the direction of laser beam different objects and also the platform itself can generate reflected beams which are detected by the LWS, generating false alarms.

So, LWS must be able to get rid of laser reflections that hit the platform after the direct beam. Electronic filtering discriminates the reflections of the main beam and other flashes of light to give an extremely low false alarm rate.

In special situations when only reflected beams are detected by the LWS, the system makes a selection between these signals and generates a direction of irradiation which is considered to be the most relevant.

5. Handle of multiple threats

Since there can be more lasers in the battlefield one very important feature which LWS must have is the capability to deal with multiple threats. The LWS control unit must be able to manage multiple threats, occurring with different delay time periods and to identify the direction of arrival and type of each threat.

6. Communication with other systems:

The LWS should be able to communicate with other systems around. It is very important to have a high speed and secure communication system in order to launch counter-measures. It's integration in different systems like BMS (Battle Management System) or communication systems allows that laser threats to be managed at a superior level.

3. Laser receivers

Laser receivers are the key component in the structure of LWS [3].

Detectors used in laser receivers are usually based on semiconductor photodiodes in different configurations and in different spectral ranges [4]. Some devices detect only main beam of incoming laser threat and other detect also

reflected rays. These scattered rays are generating signals with amplitude less than 1% of laser range finder signals. In the same time laser beam-riders and laser diode rangefinders are generating signals with comparable levels.

In our work we studied the possibility to develop an extended spectral range optical receiver having 2 PIN photodiodes at the input, one with silicon ant with InGaAs. This combination allows a good optical responsivity over a large optical spectrum from 400 nm to 1700 nm which covers the whole range of laser threats.

In Fig. 1 are presented the spectral responsivities for the 2 photodiodes and also the assembly responsivity. It can be observed that in the range from 700 nm to 1100 nm the 2 photodiodes are generating a cumulated responsivity.

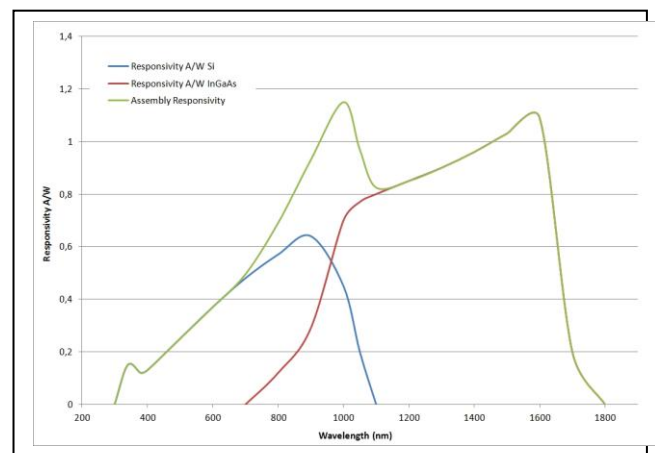

Fig. 1.

4. Experimental setup

A two level output scheme laser receiver was employed in order to obtain the discrimination between direct and reflected laser beams and rejection of the parasitic signals with amplitudes lower than the ones generated by laser reflected beams.

An analysis of the level ranges of direct and scattered laser beams must be performed prior to setting the electrical level between the two radiations.

Schematic drawing of the receiver module is presented in Fig. 2.

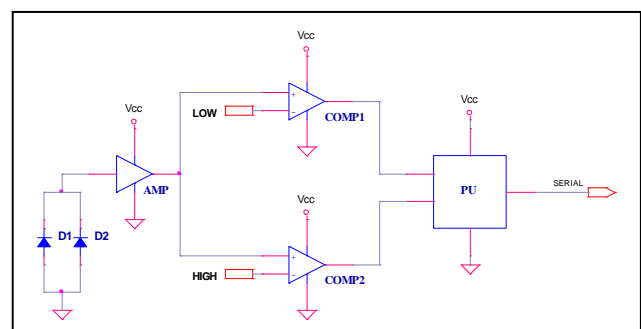

Fig. 2.

The electric signals generated by the two photodiodes are amplified and then their levels are discriminated in 2 categories corresponding to the 2 types of laser radiations: direct and reflected beams. To obtain the two categories of signals it was employed an electric scheme with two comparators.

The threshold value of discrimination between the two levels was estimated by considering that direct beams have density powers up to the level of $1\text{W}/\text{cm}^2$.

This level can be stated as a reference as many laser beams used in weapon systems have pulsed optical power around 0.2 MW and divergence of 1 mrad being used at distances of maxim 5000 m.

That means that using a photodiode with active area of approximately 1mm^2 the optical laser power incident on this area is of 0.01 W.

The level information from the comparators is processed by the microcontroller PU which transmits the results by a RS 485 serial transmission to a command and control module.

The whole optical receiver with the 2 photodiodes, amplifier and processing unit are configured in a miniaturized structure which is presented in Fig. 3.

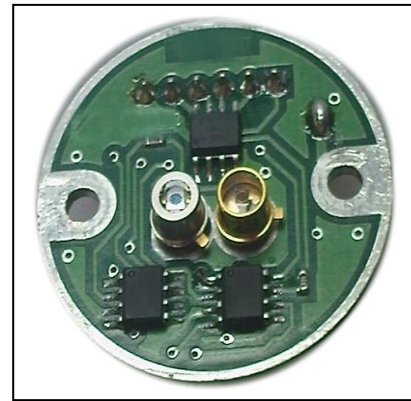

Fig. 3.

The experimental setup for testing the spectral response of the optical receiver, the optical sensibility and the threshold value between direct and reflected beams is presented in Fig. 4.

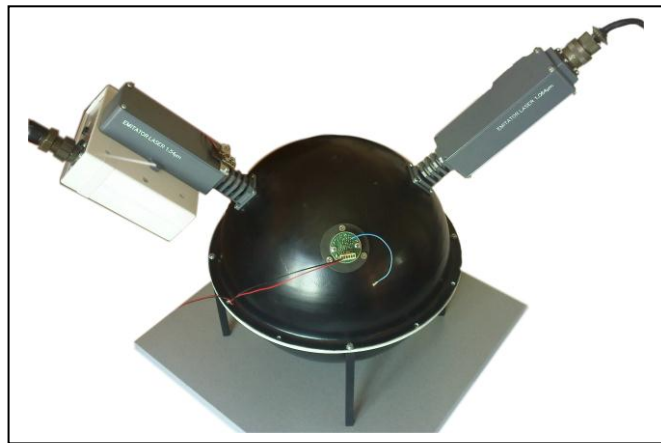
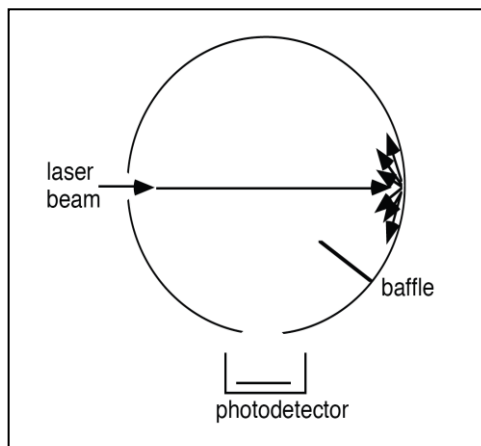

Fig. 4.

It was used an integrating sphere and 3 types of Q-switched laser sources: passively Q-switched Nd:YAG with impulse power of 2 MW at $\lambda=1064\text{nm}$, FTIR Q-switched Er:GLASS with impulse power of 0.2 MW at $\lambda=1540\text{nm}$ and a frequency doubled passively Q-switched Nd:YAG with impulse power of 0.2 MW at $\lambda=532\text{nm}$.

The laser heads were fixed on the integrating sphere on special mounts which included the attenuator filters used to obtain the desired optical power at the level of the detecting area of the photodiodes.

The integrating sphere offers the advantage of total collection and spatial integration. In the measurement of highly collimated sources such as lasers, the integrating sphere offers the advantage of important signal attenuation. The fraction of flux received by a photodetector mounted at the sphere surface is approximately the fractional surface area consumed by its active area times the sphere multiplier [5].

Sphere multiplier M is given by the formula:

$$M = \rho / (1 - \rho(1 - f))$$

ρ = sphere internal reflectance;

$$f = (A_i + A_e) / A_s;$$

A_i, A_e are input and exit ports areas;

A_s is sphere area.

For a 1mm^2 active photodiode area on a 300 mm diameter sphere with $\rho=0.95$ the optical attenuation obtained is of 6×10^{-5} .

For each of the 3 laser wavelengths were used supplementary neutral filters with the following total optical transmittances, which allowed us to obtain the threshold optical power of 0.01W at the photodiodes level:

For 532 nm radiation $T_1 \approx 0.1\%$;

For 1064 nm radiation $T_2 \approx 0.01\%$;

For 1540 nm radiation $T_3 \approx 0.1\%$.

Using the integrating sphere and the 1540 nm laser emitter with T3 filter it was set up the HIGH threshold value which separated direct and reflected laser beams.

The electrical HIGH threshold value in accordance with the electrical scheme from Fig. 2 was set up by the adjustment of the amplification, so the amplitude at the entrance of the comparator to have a default value obtained with a resistive voltage divider.

The electrical LOW threshold value was set up to reject the electrical signals with lower amplitudes than the ones obtained by significant laser reflected rays.

After setting the HIGH threshold value at 1540 nm, were operated the other laser wavelengths using the T1

and T2 filters. The HIGH laser threshold values were validated also for these radiations.

After setting up receiver amplification and the two threshold values, the laser receiver had undergone a testing process over a wide range of optical signals for the three laser wavelengths which covers most of the possible laser threats.

Testing was made using the same integrating sphere montage, and a set of 5 neutral filters, each with optical transmittance of $T=10\%$.

In Table 2 are presented optical powers calculated at the photodiodes level using the integrating sphere and the set of 5 neutral filters and in Table 3 is presented the information generated by the receiver microprocessor.

Table 2.

Wavelength nm	Pin (KW)	Pout (W) T=100%	Pout (W) T=10%	Pout (W) T=1%	Pout (W) T=0.1%	Pout (W) T=0.01%	Pout (W) T=0.001%
532	200	12	1,2	0,12	0,012	0,0012	0,00012
1064	2000	120	12	1,2	0,12	0,012	0,0012
1540	200	12	1,2	0,12	0,012	0,0012	0,00012

Table 3.

Wavelength nm	Pin (KW)	Pout (KW) T=100%	Pout (KW) T=10%	Pout (KW) T=1%	Pout (KW) T=0.1%	Pout (KW) T=0.01%	Pout (KW) T=0.001%
532	200	DB	DB	DB	DB	RB	RB
1064	2000	DB	DB	DB	DB	DB	RB
1540	200	DB	DB	DB	DB	RB	RB

DB= direct beam

RB= reflected beam

5. Conclusions

The design of laser receiver has a great influence upon the general characteristics of the Laser Warning System. These devices are mounted in different configurations in one or several modules (laser heads) distributed to cover the objective which has to be protected. Each laser receiver is designed to have a specified field of view and has it's own orientation. From their geometry results the system detection angular resolution.

The laser receiver should also allow to obtain a large range of detected laser radiations in a spectral range from visible to NIR.

The solution presented in this paper solves two important problems: a good optical responsivity covering a large spectral range from 400 to 1700 nm and also a good discrimination between reflected and direct laser beams.

The miniaturization of the receiver board allows easy integration in the laser head assembly.

Also implementation of a microprocessor processing unit at the output of the laser receiver allows a secure

serial transmission to the central processing unit, unaffected by the electrical noise.

References

- [1] Zhang Jilong, Wang Zhi-bin, Li Xiao, Tian Eerming. A Review of Laser warning Receiver Based on Spectral Discrimination and Coherent Detection, Journal of Test and Measurement Technology, **20**(2), 95 (2006).
- [2] PhD THESIS BY MUBARAK AL-JABERI, Cranfield University, 2006.
- [3] http://defense-update.com/20061214_drs-laser-receiver.html.
- [4] NEXT GENERATION LASER WARNING, November 12, 2008, Saab Avitronics.
- [5] LABSPHERE, Integrating Sphere Theory and Applications, www.labsphere.com.

*Corresponding author: elop@elop.ro