

Mechanical bleaching / quenching of luminescent centres in camphor crystals

JAGJEET KAUR, N. S. SURYANARAYANA, MEGHA DEWANGAN, VIKAS DUBEY*

Department of Physics, Govt. Vishwanath Yadav Tamaskar Post Graduate Autonomous College, Durg (C.G.), India, 491001

The emission of radiation by application of different types of stress on certain crystals and phosphors is called mechanoluminescence (ML). There are certain crystals which exhibit repetitive emission of radiation at the release and pressing of the crystal. The present paper reports that the emission of light by the repetitive application of stress on the camphor crystal. The emission takes place by the application of static stress as well as impulsive stress. In the case of both stresses, the emission is observed a number of times but with decreasing intensity. The emission was studied by the static and impulsive devices being used in our own laboratory.

(Received October 22, 2010; accepted November 10, 2010)

Keywords: Luminescence, Mechanoluminescence, Luminescent centre in camphor crystal

1. Introduction

In recent years the study of Mechanoluminescence (ML) in coloured alkali halide crystal has been become interesting because of its possible uses in radiation dosimetry, secret message writing, memory effect and in understanding the property of dislocations (Chandra 1996) [8]. To date most of the works on ML in coloured alkali halide crystals have been made during impulsive deformation of the crystals at fixed strain rates. However, the practical application requires the measurement of ML produced during the application of loads in the crystals. The present paper reports the ML produced during loading and unloading of peppermint crystal and discusses the results obtained.

In the recent past the intense elasto and fracto mechanoluminescent materials have been found to have the potential for the stress sensor, fracture sensor, damage sensor, and for the visualizations of stress field near the crack-tip, stress distribution in the solids, and quasidynamic crack-propagation in solids [9-14]. When a load is applied on to a solid, initially the ML intensity increases with time, attains a peak value and then it decreases with time. Such a curve between the ML intensity and deformation and post-deformation time of a solid is known as the ML glow curve. The present paper reports the ML glow curve of camphor crystals where the ML is induced by elastic deformation. Moreover, a comparison is made between the theoretical and experimental results, and the importance of ML glow curve is explored.

2. Experimental

Luminescence produced during mechanical deformation of camphor is undertaken to understand the mechanism of ML. The camphor which has been used is also commonly known as 'peppermint'. Its chemical formula is "HexaHydro Thymol Methyl Hydroxy Iso Propyl Cyclo Hexine Paramenthol 3 - OL". It exist in two forms

1 – Form: M.P. 41 – 43 °C; specific rotation (25 / D) to 51°
2 d1 – form: M.P. 27 – 28 °C ; specific rotation (25 / D) to +2°

The chemical structure of peppermint is

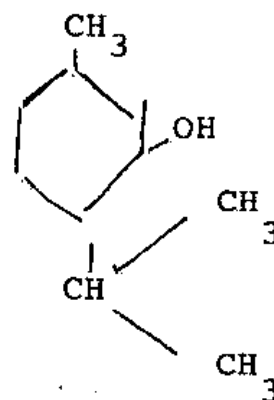

Crystals of commercial camphor were taken

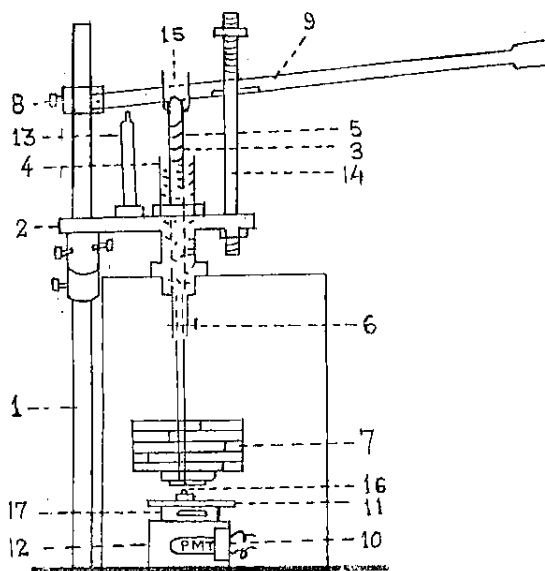

Fig. 1. (a) A schematic diagram of the device used for the determination of mechanoluminescence by static method (1) Vertical stand (2) Platform (3) Cylinder with uniform bore just fitting cylinder spring (5) Exactly fitting solid rod passing through the central hole of the platform (6) Hook for supporting hanger, (7) load and adjustable hanger, (8) clamp for lever, (9) lever rod (10) mount of the PM tube (11) glass plate for mounting the crystal (12) P.M. tube IP28 (13) adjustable rod (14) guiding rod for lever (15) guide for central rod (16) crystal (17) filter.

A solid teak wood block of the size of 4''X4''X3'' was taken. A cavity of the size of the diameter of the photomultiplier tube was made on the side surface for the broad - side on alignment, since the PM tube is of 'side-on' type. Fig. 1(a) a shielding metal cylinder having a window was put in the wooden cavity. It served two purposes: first, it provided shielding for stray voltages and second it provided safety to the photomultiplier tube. On the top of the horizontal surface a window of the same size as that of the window of the photomultiplier tube was made. A cavity was made on the top of the block to place a Lucite plate or a glass plate rigidly. The thickness of the Lucite plate and the glass plate was so chosen that the absorption of ML emission was as small as possible and it was sufficiently strong to ensure the mechanical pressure applied on the crystal placed on it. Since the ML intensity is very weak the crystals has to be near the photomultiplier tube without any risk of damage or disturbance to photomultiplier tube setting when the stress is applied or withdrawn. The ML intensity was normalized with respect to the mass of the crystals.

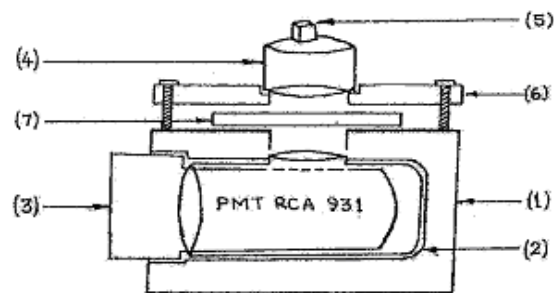

Fig. 1. (b) Photomultiplier tube housing with band pass filter for spectral studies: (1) Wooden block (2) Metal cylinder (3) P. M. Tube (4) Lucite Plate (5) Crystal (6) Metal Platform (7) space for keeping band pass filter.

The complete experiment was done in two parts. Firstly load was kept constant for different masses of the crystal and secondly mass of the crystal was kept constant for different loads. The intensity of luminescence during the application of load from the crystals was measured in terms deflection of a ballistic galvanometer which had been connected to a DC amplifier coupled to a RCA 931A photomultiplier tube. The statical loads kept on crystals were of masses 4, 8, 12 kgs respectively.

The device used for impulsive crushing is shown in Fig. 1(c).

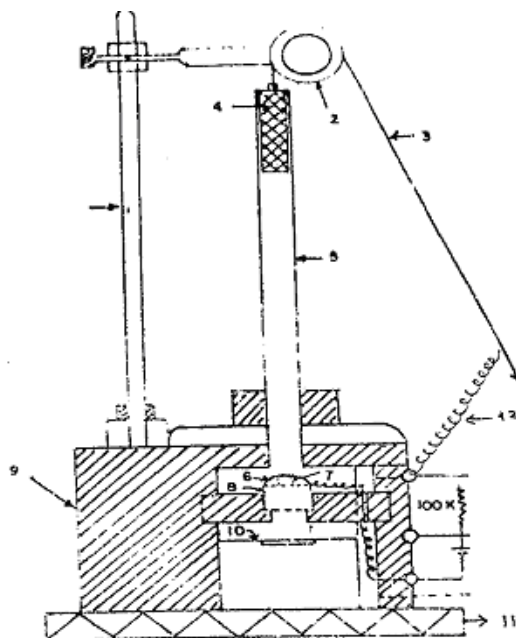

Fig. 1. (c) Schematic diagram of the experiment. Arrangement used for the measuring the time dependence of ML in crystals (1 - stand; 2 - pulley; 3 - metallic wires, 4 - load; 5 - guiding cylinder; 6 - Aluminium foil; 7 - crystal; 8 - transparent Lucite plate; 9 - wooden block; 10 - photomultiplier tube; 11 - Iron base mounted on a table).

In the case of impulsive, crushing the crystals were crushed by dropping known weights from fixed heights 10, 20, 30 cm respectively. The values of the crushing mass used were 100, 200, 500 gms respectively for each crushing height. At least three peppermint crystals were crushed in each set of observations.

In the case of repetitive statical crushing the ML intensity was measured when it was crushed first. Then the same crystal was crushed again by the same crushing mass with the height constant and its ML intensity was noted.

3. Result

The dependence of the ML intensity of peppermint crystal on the mode of mechanical crushing done in air has been shown in graph 1(d), 1(e), 1(g), 1(h). The ML intensity is observed to decrease with repeated crushing graph 1(f), 1(k).

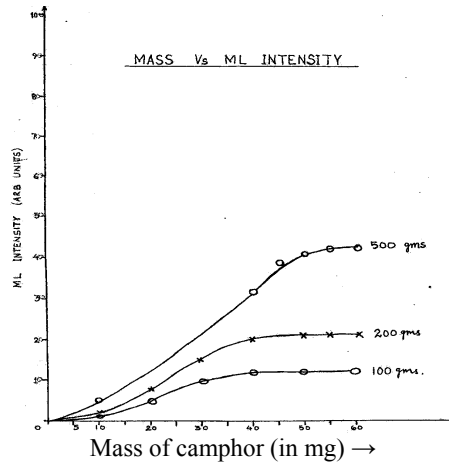

Fig. 1. (h) ML intensity of camphor with constant load, using impulsive device.

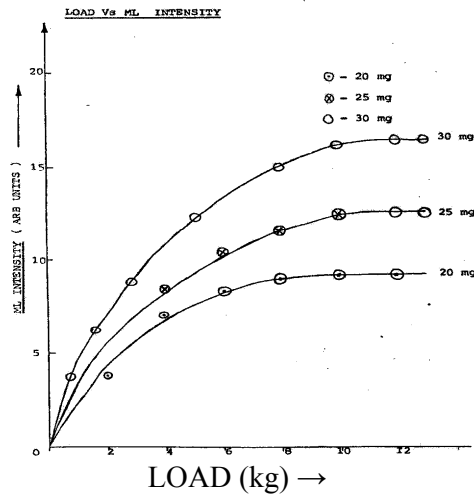

Fig. 1. (d) ML intensity of Camphor crystal with constant mass of crystal, static device.

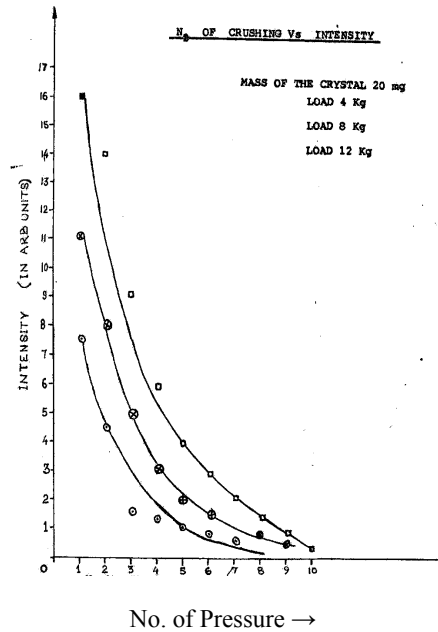

Fig. 1. (f) ML intensity of Camphor crystal with repeated crushing using static device.

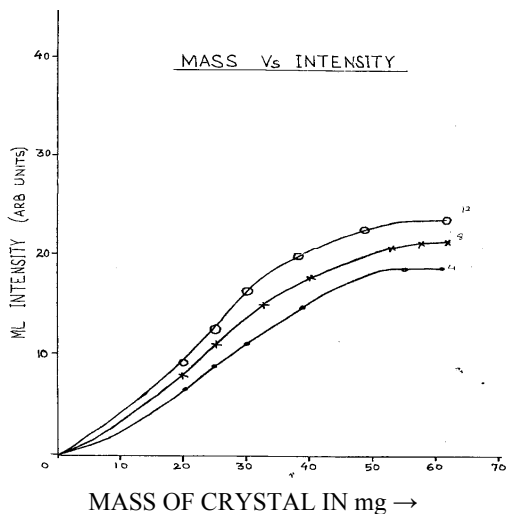

Fig. 1. (e) ML intensity of camphor with constant load using static device.

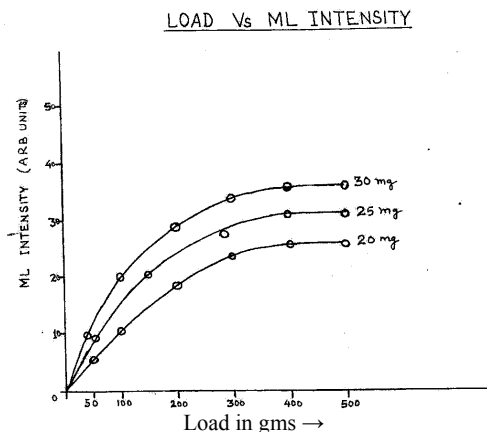

Fig. 1. (g) ML intensity of camphor crystal at constant Mass using impulsive device.

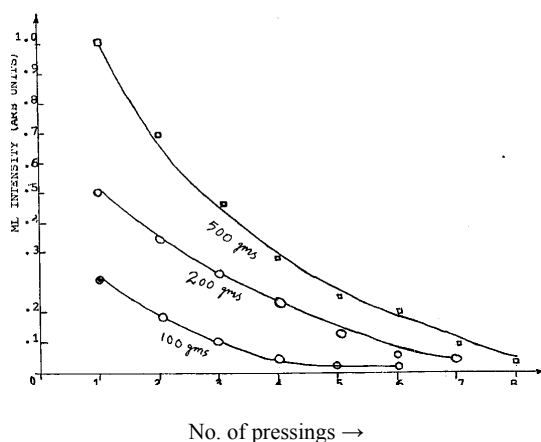

Fig. 1. (k) ML intensity of camphor crystal with repeated crushing using impulsive devices.

In the case of statical crushing done in air for a given mass of crystal, the ML intensity increases as the crushing mass increases. The ML intensity attains a saturation value after a particular value of crushing mass. In case of impulsive crushing also the same is observed, when the crushing height is kept constant. The ML intensity also increases with the crushing height.

4. Discussion

It has been observed that the ML intensity in case of peppermint crystals start getting recorded by the galvanometer when a small certain mass is either dropped or kept on the crystal so as to begin fracturing it into a crumbled mass. This suggests that when a peppermint crystal is crushed statically or impulsively the ML excitation starts occurring in it, when a certain critical value of mechanical stress is applied to it which begin fracturing it.

At higher values of stress the strain hardening takes place at a higher rate. Hence, at higher values of mechanical stress the rate of creation of new surfaces in the crystal decreases. At very high value of crushing mass the peppermint crystals get completely fractured. Further increase in crushing mass is not expected to create new surfaces due to strain hardening. Thus with higher values of crushing mass area of fractured surfaces saturates. This could be a possible reason for the ML intensity to get saturated at higher values of crushing mass in the crystals.

It is seen that as the mass of the peppermint crystals increases the ML intensity also increases. This is so because in crystals of larger mass the number of luminescence centres that are excited is large and the area of surface created due to fracture is also greater. Thus the ML intensity initially increases with the size of crystals.

In the case of repeated crushing the ML intensity decreases exponentially. The appearance of ML intensity in repeated crushing is due to the following mechanism.

During the mechanical deformation, the movement of the dislocations can take place. The movement of

dislocation may ionize the luminescent centres. Some of the free electron produced during the deformation may recombine with the holes in the crystals and may give rise to ML. However, some of the free electrons may be re-trapped in the vicinity of the defects in the crystals. The increase in number of defects with increasing number of application of mechanical stress may increase the probability of re-trapping. Re-trapping of the electrons ionized from luminescent centres is responsible for ML emission during application of stress. During the application of the stress for the second time, some of the uninhibited dislocations may move and may ionize the luminescent centres. Again ML emission as well as the re-trapping of electrons may occur during the second application of the stress. The process described above may continue and the ML may appear during repeated crushings. The inhibition of the dislocations by the free charge carriers is well known in the ionic crystals.

Thus it can be inferred that by the number of repetitive crushing the deep seated luminescent centres are made occupy shallow levels and ultimately pumped out after the emission of radiation.

References

- [1] B. P. Chandra, M. Elyas, K. K. Srivastava, R. D. Verma, 1980.
- [2] M. Elyas, B. P. Chandra, Czech J. Phys. 'B'; **34**, 163 (1984).
- [3] G. E. Ermakov, E. V. Korovkin, Yu. A. Osipyan, M. Sh. Shikhsaidou, Phys. Sol. State, **17**, 1561 (1970).
- [4] N. G. Deshmukh, Thesis submitted Ravishanker University Raipur (C.G.) entitled "Studies on the mechano luminescence of certain fluorescent and phosphorescent molecular crystal." 1985.
- [5] U. E. Karuya, Z. T. Upitis, D. B. Rikards, G. A. Teiters, Ya. L. Yansons, Mech. Compos. Mater; **17**, 236 (1981).
- [6] M. I. Molotskii, Sov. Phys. Sol. State, **20**, 956 (1978).
- [7] J. Washburn, Amer. Soc. Metals Park Ohio. 51 (1962).
- [8] B. P. Chandra, Radiation Effect and Defects in Solids **138**, 119 (1996).
- [9] B. P. Chandra, J. I. Zink, Phys. Review, **B21**, 816 (1980).
- [10] C. N. Xu, T. Watanabe, M. Akiyama, X. G. Zheng, Appl. Phys. Lett. **74**, 1236 (1999).
- [11] I. Sage, L. Humerstone, I. Oswald, Lloyd, G. Bourhill, Smart Mater. Struct. **10**, 332 (2001).
- [12] C. N. Xu, X. G. Zheng, M. Akiyama, K. Nonaka, T. Watanabe, Appl. Phys. Lett. **76**, 179 (2000).
- [13] K. S. Sohn, S. Y. Seo, Y. N. Kwon, H. D. Park, J. Am. Ceramic Soc, **85**, 712 (2002).
- [14] J. S. Kim, Y. N. Kwon, N. Shin, K. S. Sohn, Appl. Phys. Lett. **90**, 241916 (2007).

*Corresponding author: jsvikasdubey@gmail.com