

Monitoring and simulation of three-phase squirrel-cage induction motor with broken rotor bars by using virtual instruments (VIs)

KHALEEL J. HAMMADI^a, DAHAMAN ISHAK^a, SALEM BIN SAADON^{a,b*}, WAEL A. SALAH^a

^a *School of Electrical and Electronic Engineering, Universiti Sains Malaysia (USM), 14300 Nibong Tebal, Pulau Pinang, Malaysia*

^b *Collaborative Microelectronic Design Excellence Center (CEDEC), Universiti Sains Malaysia (USM), Engineering Campus 14300 Nibong Tebal, Seberang Perai Selatan, Pulau Pinang, Malaysia*

The condition monitoring of the induction motor can significantly reduced the maintenance costs by early detection of the motor's faults, which could be expensive to repair. In this paper we found some results on non-invasive detection of broken rotor bars in squirrel-cage induction motors. The applied method is so-called "motor current analysis by virtual instrument" (MCAVI) which utilizes the results of spectral analysis of the stator current. The diagnosis procedure was performed by using virtual instruments (VIs). Furthermore, this method which might help to develop diagnostics of broken bars and performance evaluation of induction motor in the near future's application.

(Received January 11, 2011; accepted March 16, 2011)

Keywords: Broken rotor bars, Faults diagnosis, Squirrel-cage induction motors, Current signatures

1. Introduction

Induction motors play an important part in the field of electromechanical energy conversion. However, the rotor broken bar fault in the motor occurs frequently. Rotor failures are caused by inadequate casting and fabrication procedure or a combination of various stresses which act on the rotor, such as electromagnetic, thermal, environmental, and mechanical. Rotor bar faults yield asymmetrical operation of induction motors causing unbalanced currents, torque pulsation, increased losses, poor starting performance and higher thermal stress. Hence, early detection of broken bars would help to avoid catastrophic failures and reduce repair cost. To study the influence of the broken-bar fault on the motor's performance characteristics, as well as in terms of the variations of the electricity spirit after rotor broken bars to examine rotor broken-bar fault is an important technical method to prevent accidents appearing in the operating process and to safeguard safety in production [1-5]. The use of line current as a parameter which can form the basis of a noninvasive condition monitoring system for the early detection of rotor faults in three phase induction motors is well established, and intensive research effort has been focused on the motor current signature analysis by VI in order to detect electrical and mechanical fault condition of induction motors [6]. The squirrel-cage induction motor which was used in this work is a 3-phase motor with, 4 poles, and 24 bars. The aims of this paper are intended to study the characteristics performance of a 1.5hp, 4 poles, 325 V, 50 Hz squirrel cage induction motor for the cases of healthy and faulty rotor conditions by LabVIEW programming method which is a effective data acquisition

device tool to solve the electromagnetic field equations under these conditions.

2. NI USB-6008 data acquisition device

LabVIEW is a graphical programming language that is suitable for developing DAQ systems using the PC plug in DAQ boards. It is an effective application for engineering in DAQ, analysis, and presentation [7-10], to prepare the software for measuring systems to be used for the measurements in real and virtual circuits. LabVIEW environment is a complex program enabling the designing and modeling of simple circuits as well as monitoring of complex manufacturing processes by means of graphical programming languages [11-14]. The designing and building of virtual devices used in computer aided measuring systems is also possible in LabVIEW environment. Thanks to special equipment (e.g. data acquisition device), the construction of the instrument panel required for testing of the real system under test is also possible [15]. Manufactured by national instruments was used in order to record real diagnostic signals originating from the instrument panel installed in the laboratory test stand. The data acquisition device is provided with 8 single analogue inputs or with 4 differential programmable analogue inputs, 2 analogue outputs and 12 programmable digital I/O systems. The information received from the inputs or outputs control signals is sent to the control unit (PC) by means of USB line. The signal transmitted between the data acquisition device and PC conforms to full-speed USB standard. The layout of NI USB-6008 data acquisition device was illustrated in Fig. 1 and the block diagram of a test stand was illustrated in Fig. 2.



Fig. 1. NI USB-6008 data acquisition device.

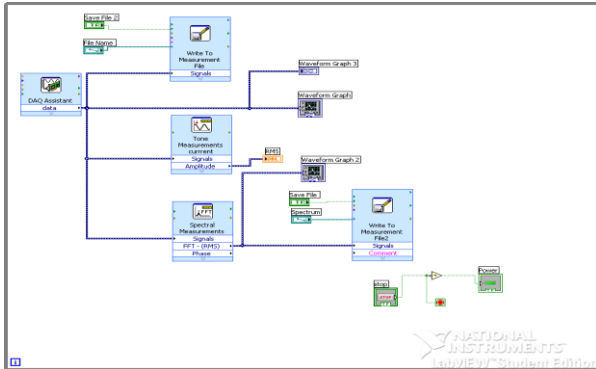

Fig. 2. Block diagram of the created virtual instrument panel analogical.

3. Signal processing and analysis

After LabVIEW acquire the voltage and current waveform from the NI-6008 (USB) DAQ board, the fundamental element such as the DC value, the Peak Value, the RMS Value, the phase angle, the frequency is extracted. From the phase angle, the power factor is obtained by using Eq. (1). [16].

$$PF = \cos(\theta_v - \theta_i) \tag{1}$$

where,

- PF: Power factor
- θ_v : Phase angle of voltage
- θ_i : Phase angle of current

From eq. (1), the real power, the reactive power and the apparent power can be calculated according to Eq. (2).

$$S = V.I \tag{2}$$

$$P = S.PF \tag{3}$$

$$Q = \sqrt{S^2 - P^2} \tag{4}$$

Where,

- S: Apparent power
- P: Real power
- Q: reactive power

In addition, the resistance and the reactance of the motor winding are also able to be calculated [17].

$$R = \frac{P}{I^2} \tag{5}$$

$$X = \frac{Q}{I^2} \tag{6}$$

where,

- R: Resistance
- X: Reactance

Harmonic is one of the important measurements in motor test bench as harmonic has significant effect on motor design.

This project involves the development of LabVIEW modules for DAQ and analysis for AC motor test bench. The block diagram of the created virtual instrument panel analogical to the instrument panel installed with three phase squirrel cage induction motor parameters was illustrated in Table 1. In order to improve the circuit diagram transparency, some of its elements were combined into a form of subprograms containing a part of input or output elements. Configuration of the data acquisition device ports and performing the conversions required to adapt the input signal parameters to the ranges of indicators and warning lamps. The individual subprograms used in the main simulation program are characterized by precisely specified functions enabling quick connection between individual elements without any necessity to analyses their inner block diagrams.

For the motor test, it is to apply the proposed LabVIEW interfaced module to motor to ensure its performances in real life motor at healthy and faulty condition. The line current, of the motor is measured by the proposed LabVIEW interfaced module, the results already are compared.

4. Simulation and test results of a Variable Load with 4 broken bars

In order to make several measurements with healthy and faulty squirrel-cage induction motors a modern laboratory test bench was set up. It consists of two coupled electrical motors; the motor to be tested and a DC motor fed by a controlled rectifier used for loading are given in Fig. 7.

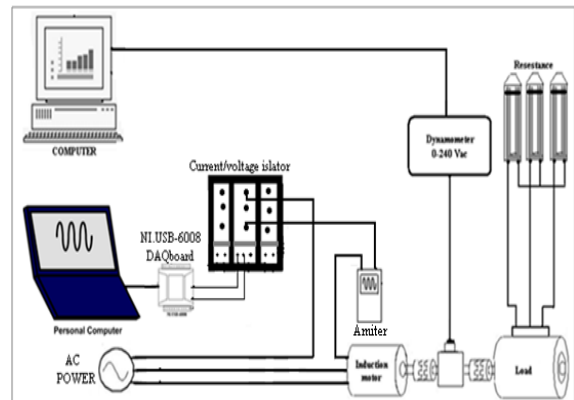

Fig. 7. The layout of the circuit for the experiment.

Several virtual instruments (VIs) were built up in LabVIEW. These VIs were used both for controlling the test measurements and data acquisition, and for the data processing. The VI created for processing and analyzing the acquired data from the test bench is given in Fig. 2.

The rated data of the tested three-phase squirrel cage induction machine was illustrated in Table 1.

Table 1. Squirrel-cage induction motor parameter.

Number of poles	4
Number of phases	3
Outer diameter of stator	140 mm
Inner diameter of stator	76 mm
Air gap length	0.6 mm
Axial length	52.6 mm
Number of stator slots	24
Number of rotor bars	24
Rated voltage (V) rms	325
Rated frequency (Hz)	50

Tests were carried out for different loads with the healthy motor, and with similar motors having up to 4 broken rotor bars. The current waveform can be visualized clearly on the waveform chart and the harmonic component can also be observed on the harmonic chart as shown in Figs. 3, 4, 5, 6 respectively. As it can be seen from the figures the waveform graph at no-load (and also at loads).

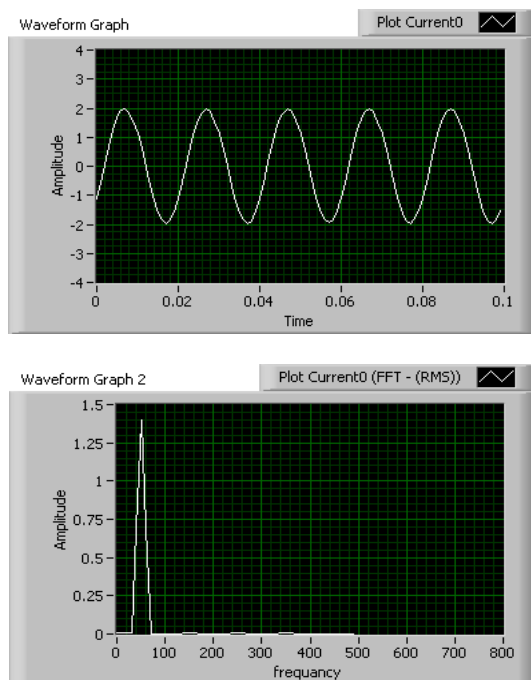

Fig. 3. Stator current waveform and current spectrum in healthy state motor without load under speed 1480 rpm.

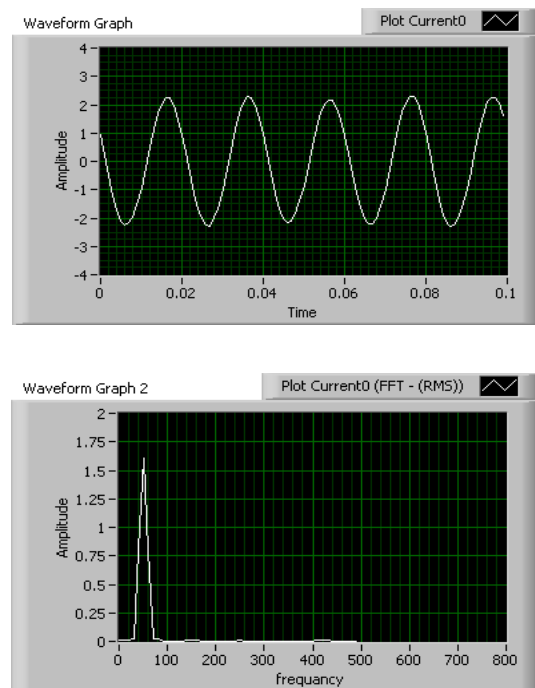

Fig. 4. Stator current waveform and current spectrum in healthy state motor with load under speed 1395 rpm

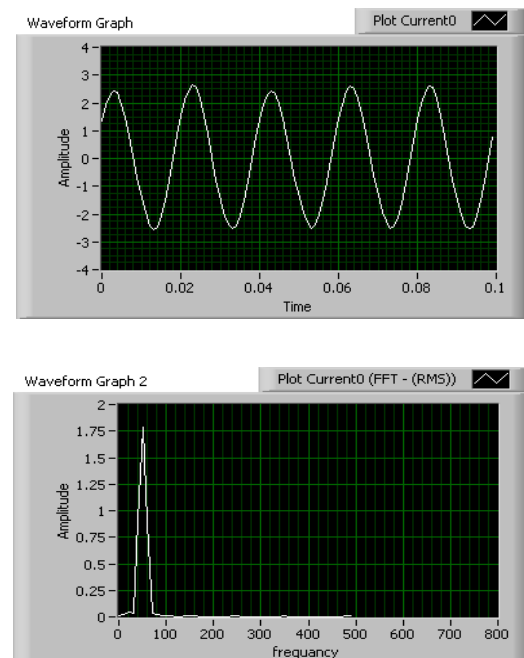

Fig. 5. Stator current waveform and current spectrum in faulty state motor without load under speed 1325 rpm.

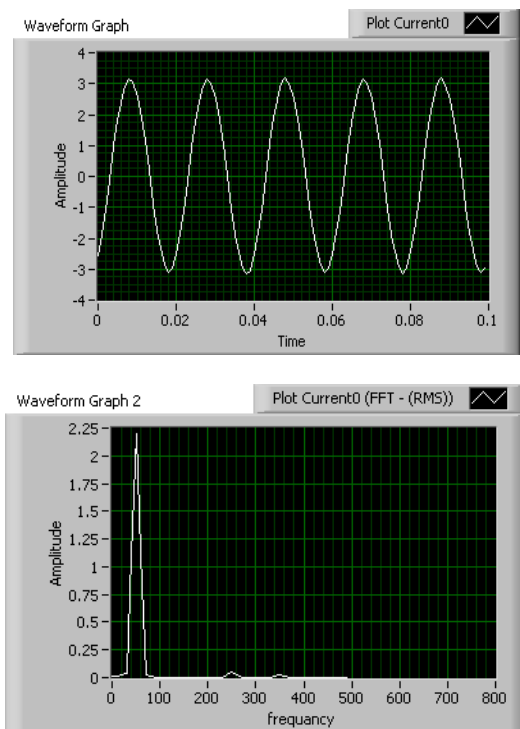

Fig. 6. Stator current waveform and current spectrum in faulty state motor with load under speed 1225 rpm.

5. Conclusions

Because of its overall versatility as an engineering tool, the software package LabVIEW is chosen in most of the engineering problems. It is a graphical programming language that allows engineers and scientists to develop their own virtual instrument, which is flexible, modular and economical. Furthermore, the software meets most of the software selection criteria, and it not only does the data manipulation, analysis, and control, but also has some multimedia authoring capabilities with the help of the add-on tools. The LabVIEW software allows for the creating of application-specific templates (sub-virtual instruments) to reduce the production time for the identical subjects. Many useful functions can be incorporated with the LabVIEW programs to perform very useful tasks in a laboratory virtual instrumentation system design.

6. Future work

The LabVIEW-based motor test bench is very suitable for both academic experiment and research application. The LabVIEW based motor test bench can be further improved by having more features like temperature monitoring, speed detection and other features. Besides that, further improvement on application of digital and analog output of the NI-6008 (USB) DAQ board with some relays can make the system gain ability to control the motor for experiment and protection purpose.

References

- [1] K. Kim, A. G. Parlos, Mechanical Systems and Signal Processing, **16**(2-3), 223 (2002).
- [2] S. Nandi, H. A. Toliyat, Proceedings of the IEEE-IEMDC'99 Conference, Seattle, pp. 219 (1999).
- [3] W. T. Thomson, R. J. Gilmore, Proceedings of 32nd Turbomachinery Symposium, Texas, A&M University, USA (2003).
- [4] J. Milimonfared, et al., IEEE Transactions on Industry Applications, **35**(5), 1000 (1999).
- [5] L. Szabó, K. Á. Bíró, J. B. Dobai, Oradea University Annals, Electrotechnical Section, 313 (2003).
- [6] D. Marsh, EDN Europe, **10**(2), (2003).
- [7] L. Szabó, K. Á. Bíró, J. B. Dobai, Proceedings of the International Scientific Conference MicroCAD '2003, Miskolc (Hungary), Section J (Electrotehnics and Electronics), pp. 81-86 (2003).
- [8] W. T. Thomson: Keynote address at IEEE Symposium on Diagnostics for Electrical Machines, Power Electronics and Drives, Gijon, Spain, pp 3-18 Sept. 1999.
- [9] K. Kim, A. G. Parlos, Mechanical Systems and Signal Processing, **16**(2-3), 223 (2002).
- [10] L. Szabó, K. Á. Bíró, J. B. Dobai, Oradea University Annals, Electrotechnical Section, pp. 313-320 (2003).
- [11] N. I. Developer, Real-time monitoring & analysis of harmonics in single-phase systems, retrieved 27 July 2009, from <http://digital.ni.com/worldwide/singapore.nsf/web/all/146D609A8B8C4C00862574D7003F6341>, (2006).
- [12] J. S. Benton, Virtual instrument measures harmonic filter duty. Computer Applications in Power, IEEE, **8**, 43 (1995).
- [13] T. Jen-Hao, C. Shun-Yu, L. Jin-Chang, R. Lee, (2000) A LabVIEW based virtual instrument for power analyzers. Power System Technology, 2000. Proceedings. PowerCon 2000. International Conference on.
- [14] M. Kostic, LabVIEW and data acquisition, retrieved 27 July 2009, from <http://www.kostic.niu.edu/DAQ-LabVIEW.html>
- [15] R. K. Manoj Embrandiri, C. V. Aravind, Harmonic distortion analysis in LabVIEW, (2006).
- [16] K. Omata, Y. Fujita, N. Yoshikawa, M. Sekiguchi, Y. Shida, A data acquisition system based on a personal computer. Nuclear Science, IEEE Transactions on, **39**, 143-147 (1992).
- [17] S. Cincotti, M. Marchesi, A. Serri, A LabVIEW-based laboratory course on three-phase electric machinery under unsymmetrical operating conditions, EPE'97, 7th Eur. Conf. Power.

*Corresponding author: saadonsalem@yahoo.com